



**JAECO**  
*Orthopedic*



**Setup Instructions**  
**for**  
**MultiLink Mobile Arm Supports**



**JAEKO**  
**Orthopedic**

**Active healthcare solutions Ltd.**

Unit 163 - 5489 Byrne Road  
Burnaby, BC. V5J 3J1

Canada

[Info@activehs.ca](mailto:Info@activehs.ca)

[Activehs.ca](http://Activehs.ca)

# Table of Contents

## **Section 1:**

Mobile Arm Support Mounts

## **Section 2:**

Forearm Support with Offset Swivel & Slide

## **Section 3:**

MultiLink Mobile Arm Support

Right Setup

Left Setup

## **Section 4:**

MultiLink with Elevation Assist Mobile Arm Support

Right Setup

Left Setup

## **Section 5:**

Basic Adjustments for Functional Use of the MultiLink MAS  
with Elevation Assist

Adjusting Elevation Right Side

Adjusting Elevation Left Side

MultiLink with Elevation Assist Rubber Band Setup

## **Section 6:**

Basic Adjustments for Functional Use of the MultiLink MAS

Horizontal Movements

Vertical Movements

## **Section 7:**

Finalizing Setup

## **Section 8:**

Special Circumstances and Alternatives

Arm Height Adjuster

## **Section 9:**

JAECO Mount Relocators

Mount Relocator for tubular back posts

Mount Relocator for molded backrests

Mount Relocator for keyed back posts

# **Section 1 Mobile Arm Support Mounts**

# JAECO / Rancho Mount Setup



## Parts Description

**Top View**  
**Mounted on Right Side of Wheelchair**

**Top View**  
**Mounted on Left Side of Wheelchair**

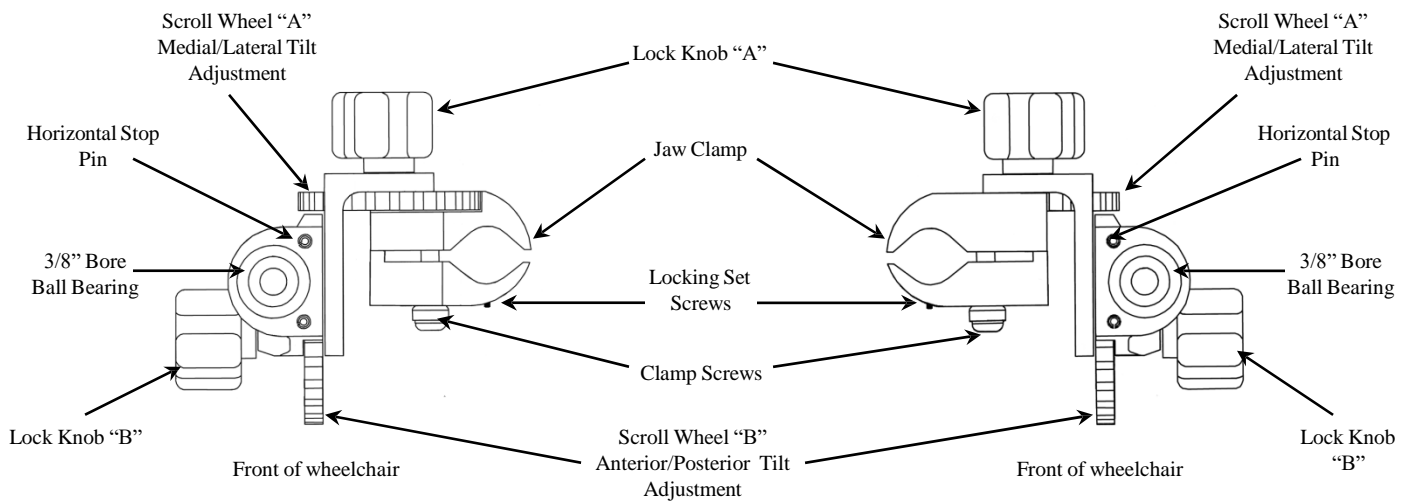

# Mount Installation

## Preparing Mount

Loosen Clamp Screws with large T-Wrench

**Do not remove screws** and open clamps to their widest position by pushing the moveable jaw forward and pulling it outward as shown in picture.

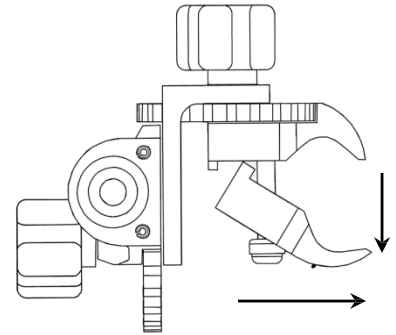

## Mount Attachment

1. In this open position, apply mount to wheelchair upright (back post) or to a Mount Relocator, if required.
2. Position mount so that the top of the mount is at patient's mid humeral region.

**Note:** *Adjustments in position may be necessary for optimal function.*



## Securing Mount

- Tighten Clamp Screws with Scroll Wheel "B" in line with the arm rest of the wheelchair.
- **Do not tighten Locking Set Screws at this time.**
- Adjustments may be necessary to achieve optimal functional use of the mobile arm support.

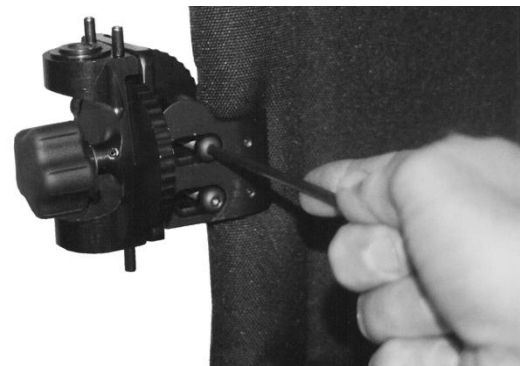

# JAECO Table Mount Setup

## Parts Description

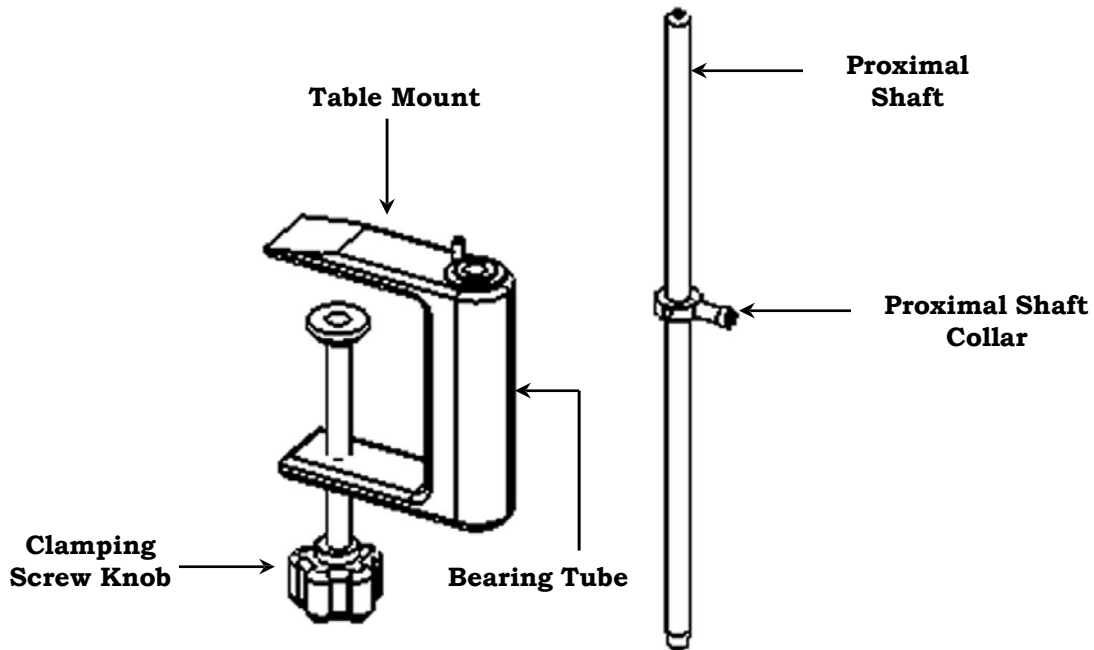

## Mount Installation:

1. Turn the Clamping Screw Knob counter clockwise to open the “jaw” of the mount.
2. Slide the mount over the edge of the table, with the Clamp Screw Knob facing down, until the mounts Bearing Tube touches the edge of the table. Turn clamping Screw clockwise until the mount is firmly attached to the table.
3. Insert the long Proximal Shaft (supplied with the Table Mount) through the bearing tube and insure the proximal shaft protrudes through the lower bearing.
4. Refer to section 3 for MultiLink Arm setup or section 4 for MultiLink with Elevation Assist setup.

**Note:** *The Proximal Shaft Collar will be used for height and lateral stop adjustment.*

*When Table Mount is used with JAECO Original Table Mount MAS the long Proximal Shaft will not be used, but the Proximal Shaft Collar may be needed.*

# **Section 2**

## **Forearm Support with Offset Swivel & Slide**

# Forearm Support with Offset Swivel Right Side Setup

## Right View

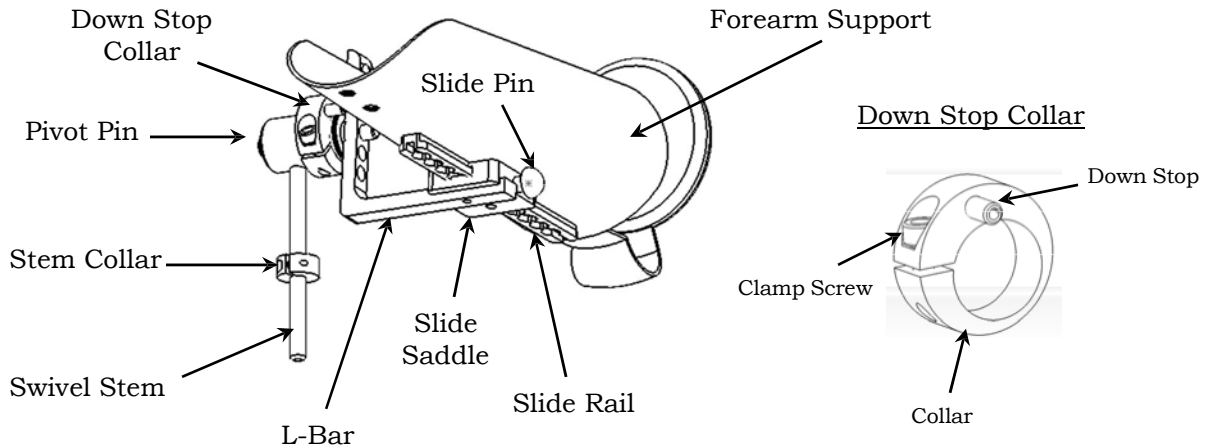

- When removed from packaging the Forearm Support will be set up for the Right Side and the Proximal Screw will be tight and the Distal Screw loose.
- If using for the right side tighten Distal Screw now.
- When setting up for the left side refer to page 2-2 Left Side Setup.

## Distal Screw Proximal Screw

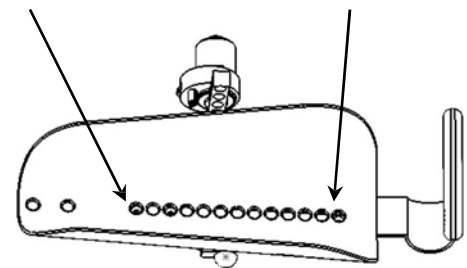

Top View Right Side

If not assembled:

1. Depress Slide Pin and insert Slide Rail into Slide Saddle track
2. Using a flat blade screw driver, tighten Distal Screw.

**Note:** If Slide Rail will not slide through Slide Saddle, insure that the Slide Pin is fully depressed or it may be necessary to loosen the Distal Screw.

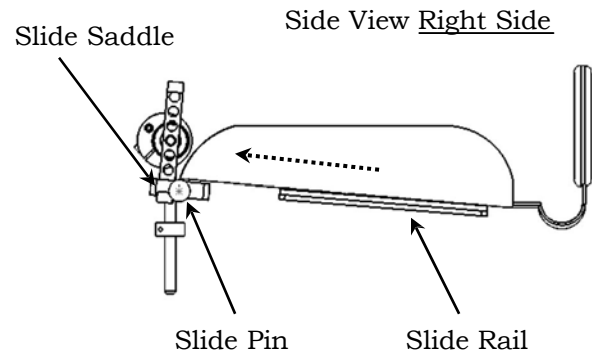

# Forearm Support with Offset Swivel Left Side Setup

## Left View

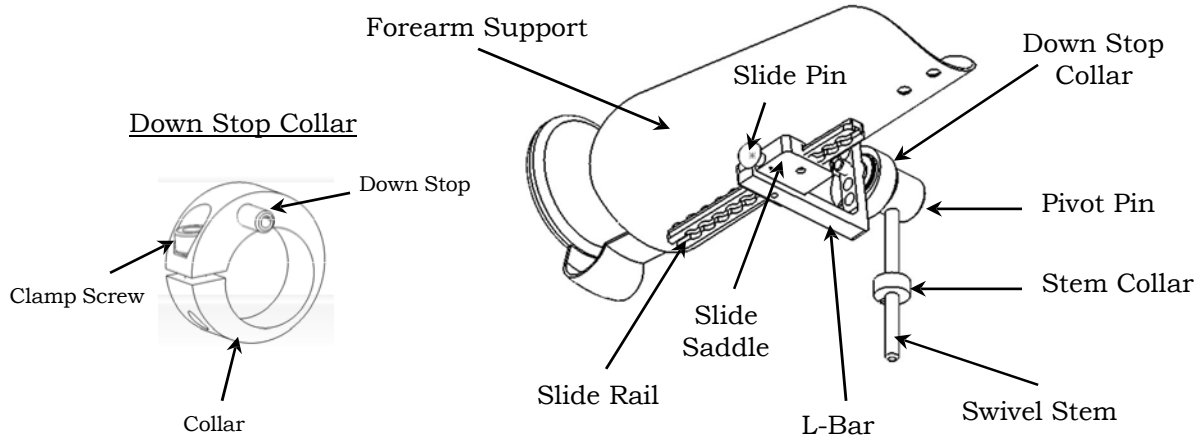

When removed from packaging the Forearm Support will be set up for the Right Side and the Proximal Screw will be tight and the Distal Screw loose.

### Left Side Setup:

1. Insure the Distal Screw is loose and slide the forearm support out of Slide Saddle and reinsert back into the Slide Saddle the opposite direction.
2. Using a flat blade screw driver, Tighten Distal Screw

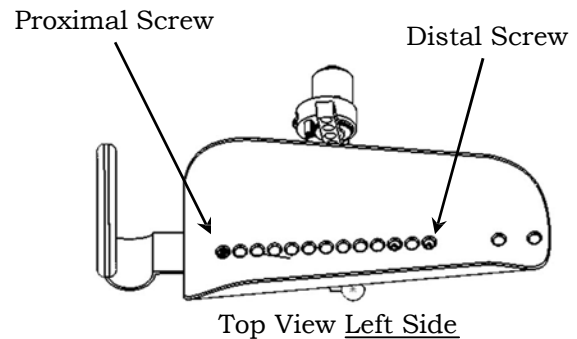

If not assembled:

1. Depress Slide Pin and insert Slide Rail into Slide Saddle track
2. Using a flat blade screw driver, tighten Distal Screw.

**Note:** *If Slide Rail will not slide through Slide Saddle, insure that the Slide Pin is fully depressed or it may be necessary to loosen the Distal Screw.*

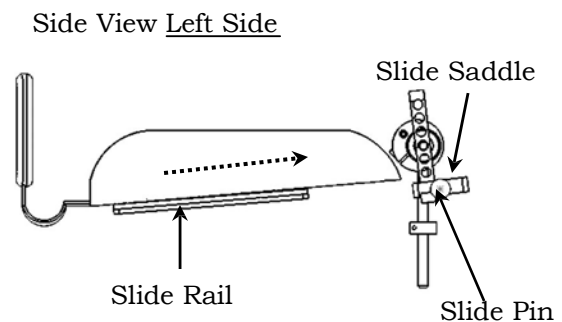

# **Section 3 MultiLink Mobile Arm Support**

# MultiLink Arm Setup

## Parts Description Top Right View

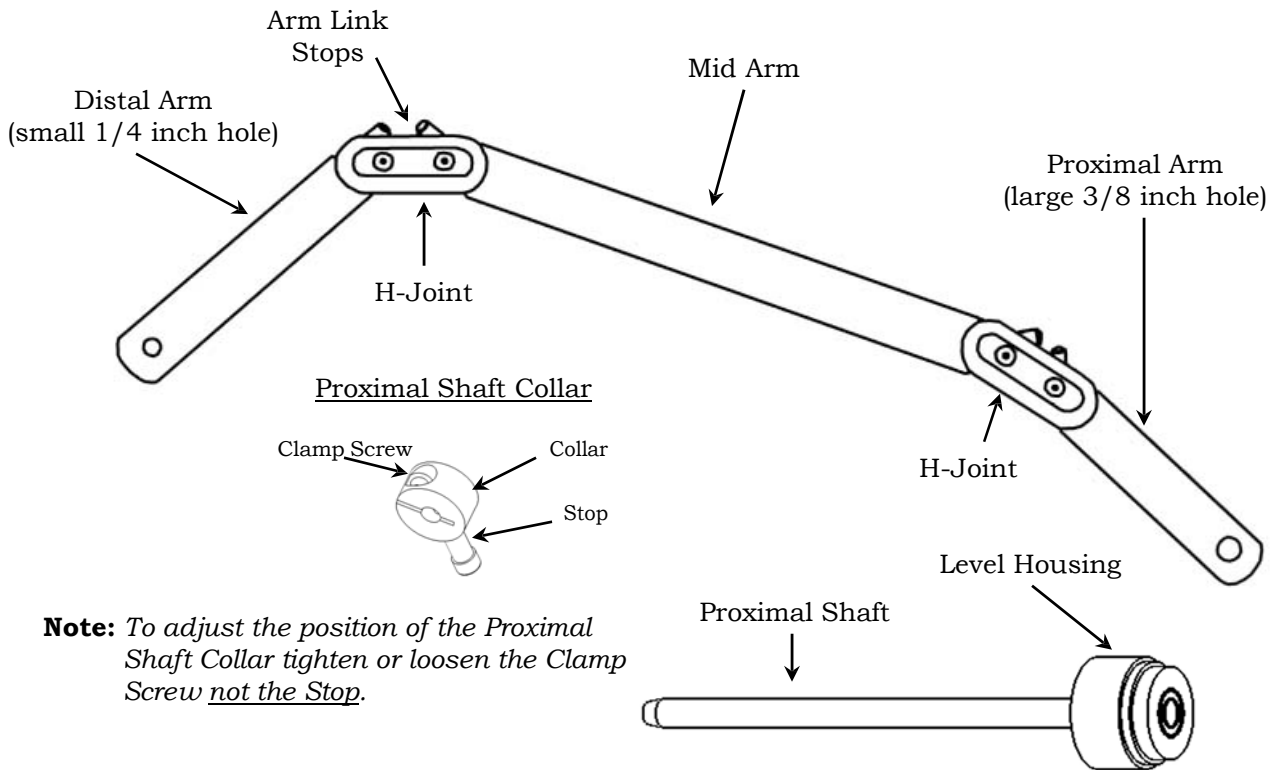

**Note:** To adjust the position of the Proximal Shaft Collar tighten or loosen the Clamp Screw not the Stop.

## MultiLink Assembly Right Side

1. Lay Multilink Arm on table with Proximal Arm (shortest arm with largest hole) pointing toward you with the Distal Arm pointing to your Left.

**Note:** Multilink arm is designed to be universal Rt or Lt. It is not necessary to remove Arm Link Stops for setup.

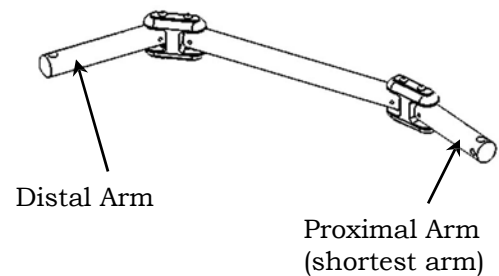

2. Insert Proximal Shaft into through the 3/8 inch diameter hole of the Proximal Arm until the Level Housing rests on top of the arm.
3. Secure the Proximal Shaft to the arm by tightening the Set Screw using large T-Wrench

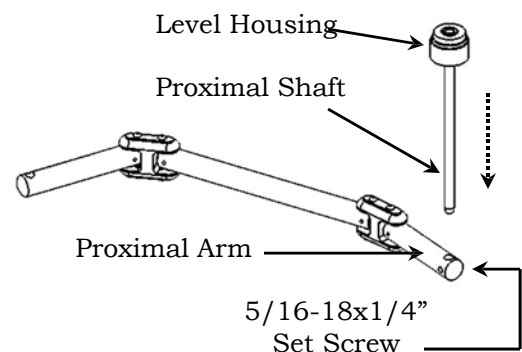

- Slide the Proximal Shaft Collar up the Proximal Shaft. The Proximal Shaft Collar will be used for height and lateral stop adjustment.

**Do not tighten the Clamp Screw at this time.**

**Note:** *The Proximal Shaft Collar must be used even if you do not need it to limit the lateral movement of the patient's arm.*

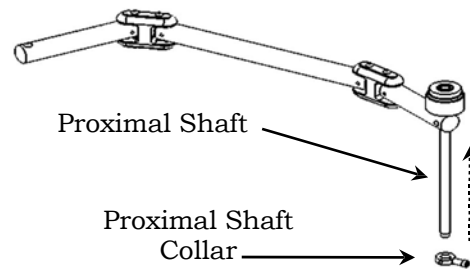

- With mount attached (page 1-2) to the right side of wheelchair insert Proximal Shaft into the Ball Bearing Housing.

**Note:** *Insure the Proximal Shaft protrudes through lower ball bearing.*

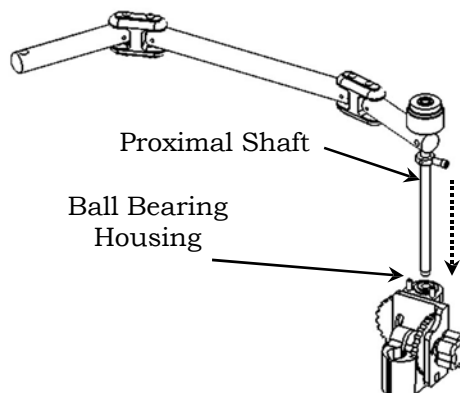

- Insure that the Stem Collar (pictured on page 2-1) is on the Swivel Stem. Insert Swivel Stem into the 1/4" hole of Distal Arm.

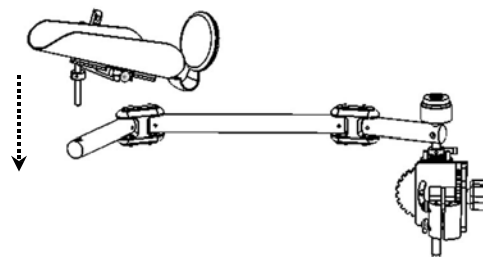

- Standing in front of the wheelchair, the Multilink Mobile Arm Support should resemble the picture to the right.

**Note:** *Lock knob "A" on the mount may be showing if it was set up with lock knob "A" facing the front of wheelchair.*

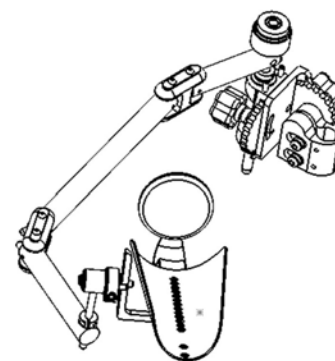

- When optimum adjustments have been made (refer to page 7-1) Secure the settings.

# MultiLink Arm Setup

## Parts Description Top Left View

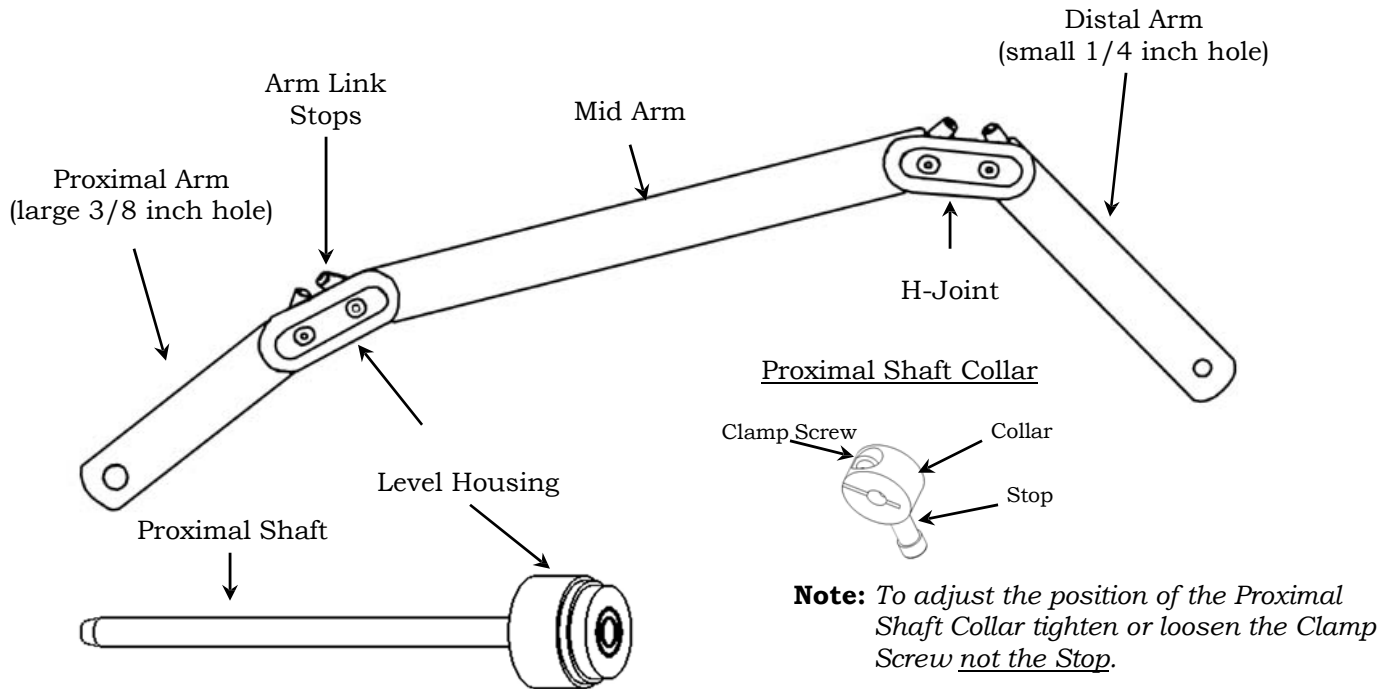

## MultiLink Assembly Left Side

1. Lay Multilink Arm on table with Proximal Arm (shortest arm with largest hole) pointing toward you with the Distal Arm pointing to your Right.

**Note:** Multilink arm is designed to be universal Rt or Lt.  
It is not necessary to remove Arm Link Stops for setup.

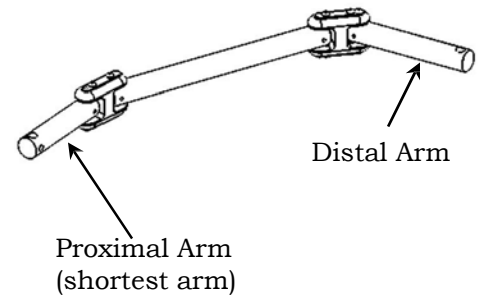

2. Insert Proximal Shaft into through the 3/8 inch diameter hole of the Proximal Arm until the Level Housing rests on top of the arm.
3. Secure the Proximal Shaft to the arm by tightening the Set Screw using large T-Wrench

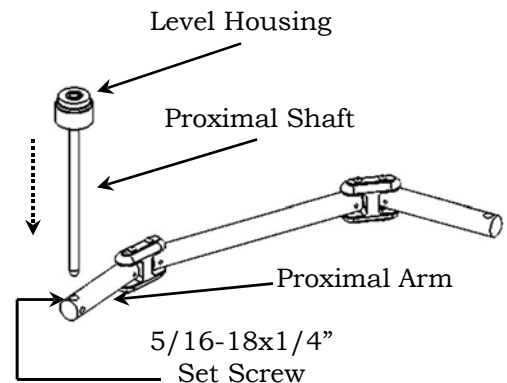

- Slide the Proximal Shaft Collar up the Proximal Shaft. The Proximal Shaft Collar will be used for height and lateral stop adjustment.

**Do not tighten the Clamp Screw at this time.**

**Note:** *The Proximal Shaft Collar must be used even if you do not need it to limit the lateral movement of the patient's arm.*

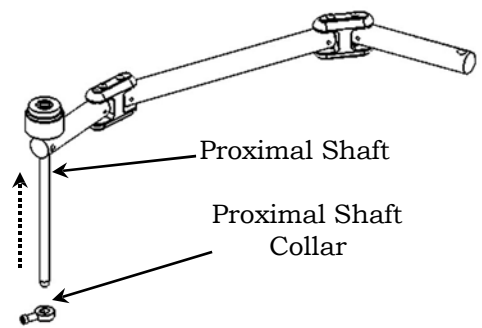

- With mount attached (page 1-2) to the left side of wheelchair insert Proximal Shaft into the Ball Bearing Housing.

**Note:** *Insure the Proximal Shaft protrudes through lower ball bearing.*

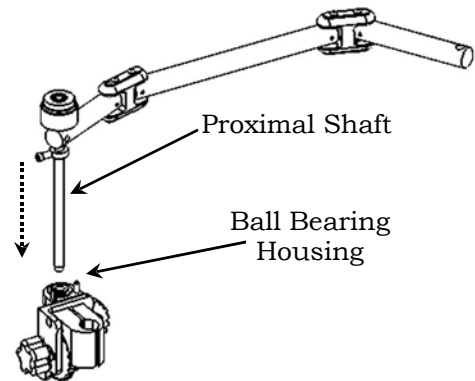

- Insure that the Stem Collar (pictured on page 2-2) is on the Swivel Stem. Insert Swivel Stem into the 1/4" hole of Distal Arm.

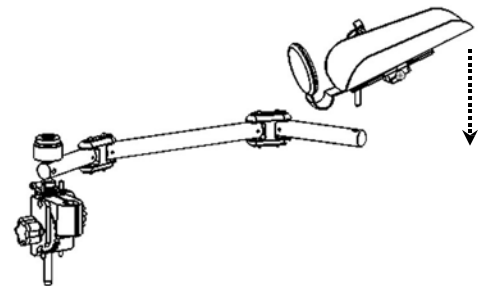

- Standing in front of the wheelchair, the Multilink Mobile Arm Support should resemble the picture to the right.

- When optimum adjustments have been made (refer to page 7-1) Secure the settings.

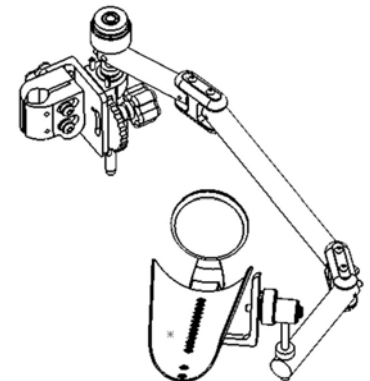

# **Section 4**

## **MultiLink with Elevation Assist Mobile Arm Support**

# MultiLink Arm with Elevation Assist Setup

## Parts Description Right View

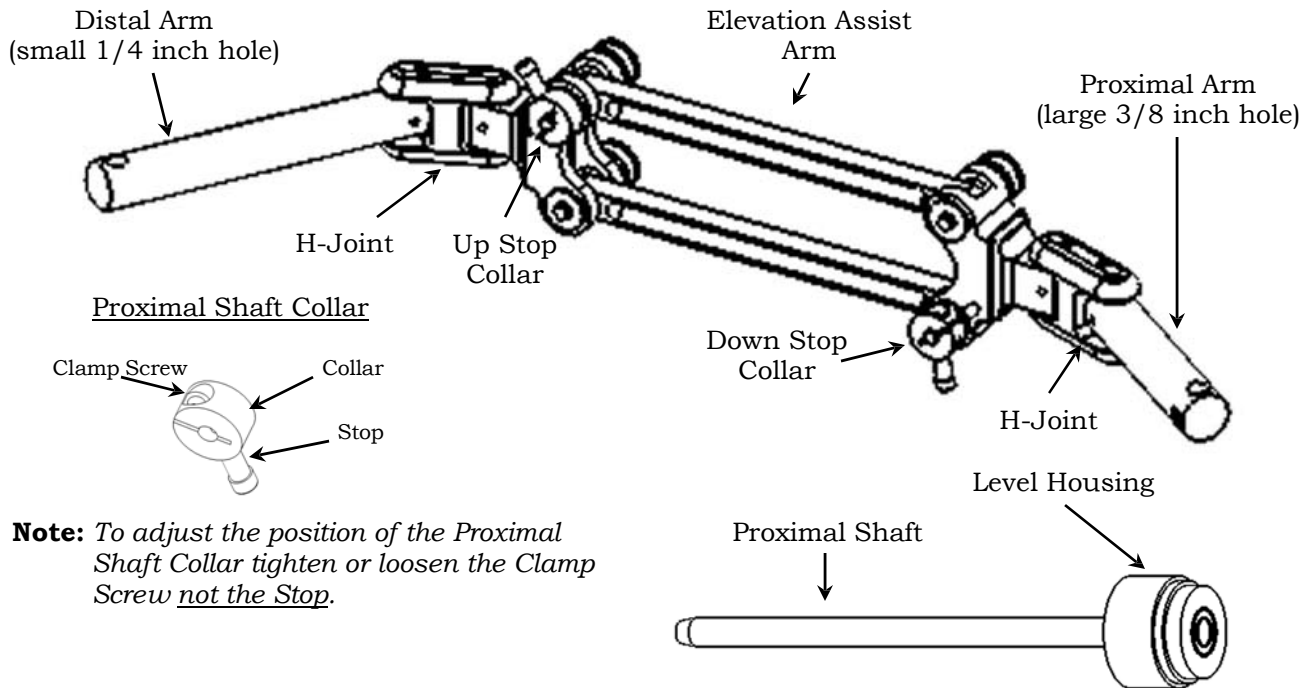

## MultiLink with Elevation Assist Assembly Right Side

1. Lay Multilink Arm on table with Proximal Arm (shortest arm with largest hole) pointing toward you with the Distal Arm pointing to your Left.

**Note:** Multilink arm is designed to be universal Rt or Lt.  
It is not necessary to remove Arm Link Stops for setup.

2. Insert Proximal Shaft into through the 3/8 inch diameter hole of the Proximal Arm until the Level Housing rests on top of the arm.
3. Secure the Proximal Shaft to the arm by tightening the Set Screw using large T-Wrench

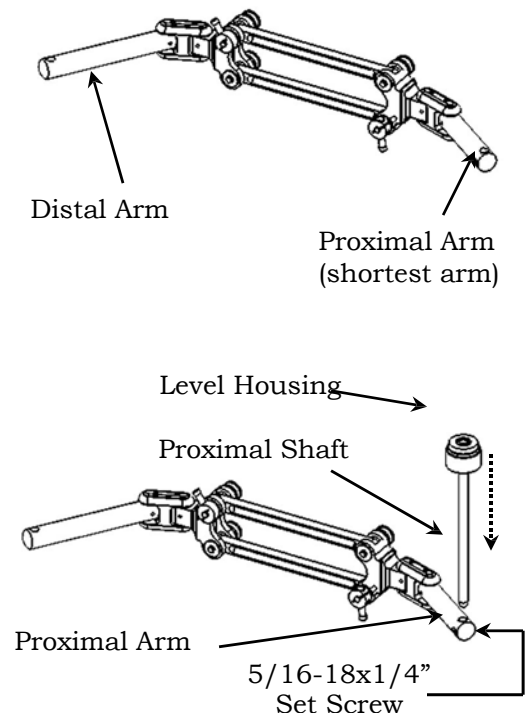

- Slide the Proximal Shaft Collar up the Proximal Shaft. The Proximal Shaft Collar will be used for height and lateral stop adjustment.

**Do not tighten the Clamp Screw at this time.**

**Note:** *The Proximal Shaft Collar must be used even if you do not need it to limit the lateral movement of the patient's arm.*

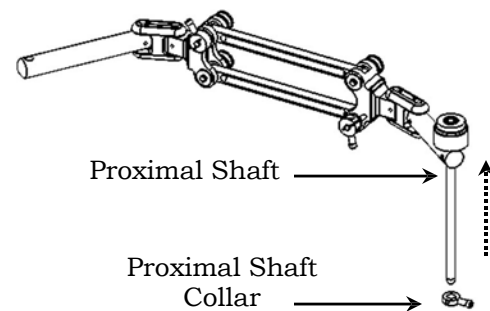

- With mount attached (page 1-2) to the right side of wheelchair insert Proximal Shaft into the Ball Bearing Housing.

**Note:** *Insure the Proximal Shaft protrudes through lower ball bearing.*

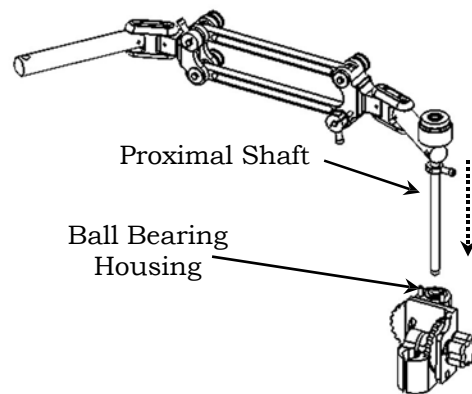

- Insure that the Stem Collar (pictured on page 2-1) is on the Swivel Stem. Insert Swivel Stem into the 1/4" hole of Distal Arm.

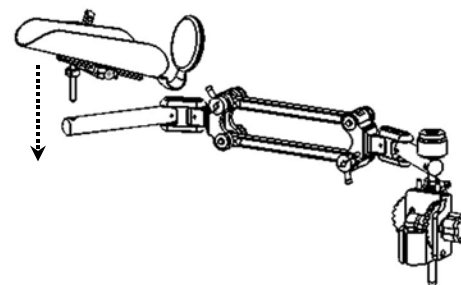

- Standing in front of the wheelchair, the Multilink Mobile Arm Support should resemble the picture to the right.

- When optimum adjustments have been made (refer to page 7-1) Secure the settings.

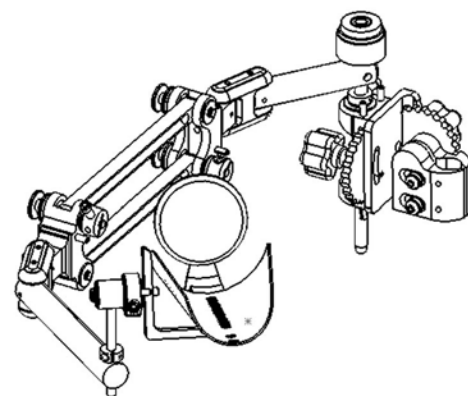

# MultiLink Arm with Elevation Assist Setup

## Parts Description Left View

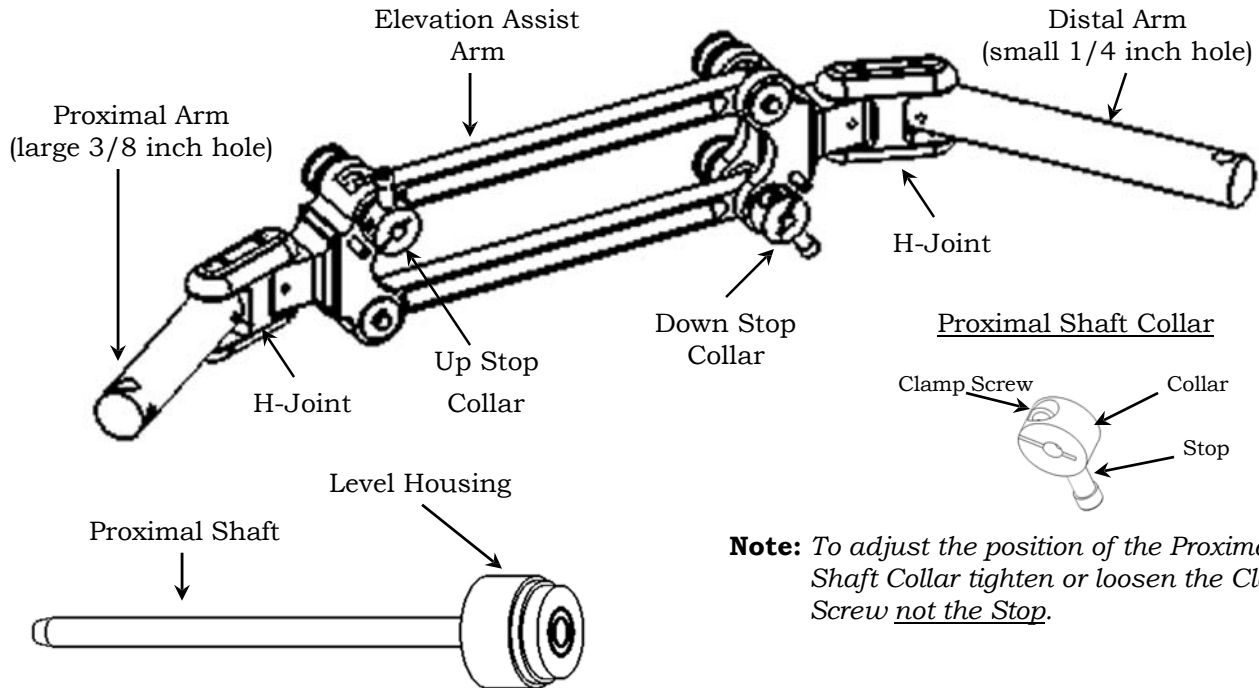

**Note:** To adjust the position of the Proximal Shaft Collar tighten or loosen the Clamp Screw not the Stop.

## MultiLink with Elevation Assist Assembly Left Side

1. Lay Multilink Arm on table with Proximal Arm (shortest arm with largest hole) pointing toward you with the Distal Arm pointing to your Right.

**Note:** Multilink arm is designed to be universal Rt or Lt.  
It is not necessary to remove Arm Link Stops for setup.

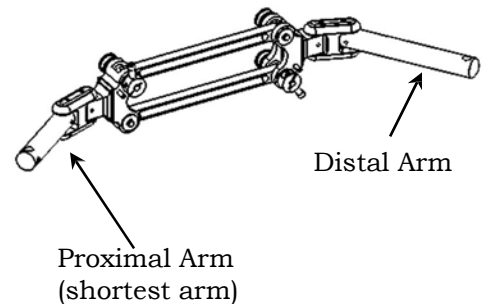

2. Insert Proximal Shaft into through the 3/8 inch diameter hole of the Proximal Arm until the Level Housing rests on top of the arm.
3. Secure the Proximal Shaft to the arm by tightening the Set Screw using large T-Wrench

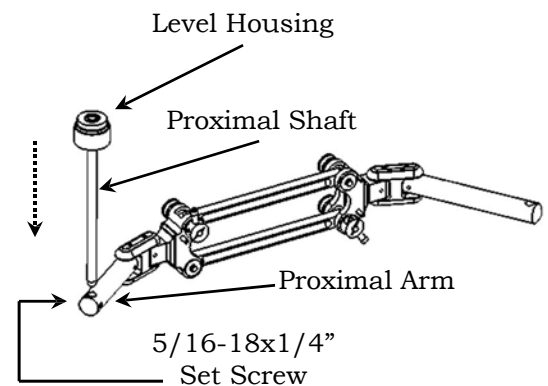

- Slide the Proximal Shaft Collar up the Proximal Shaft. The Proximal Shaft Collar will be used for height and lateral stop adjustment.

**Do not tighten the Clamp Screw at this time.**

**Note:** *The Proximal Shaft Collar must be used even if you do not need it to limit the lateral movement of the patient's arm.*

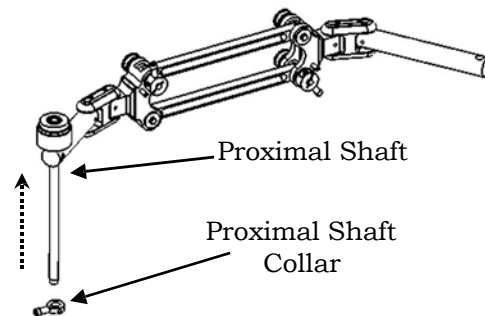

- With mount attached (page 1-2) to the left side of wheelchair insert Proximal Shaft into the Ball Bearing Housing.

**Note:** *Insure the Proximal Shaft protrudes through lower ball bearing.*

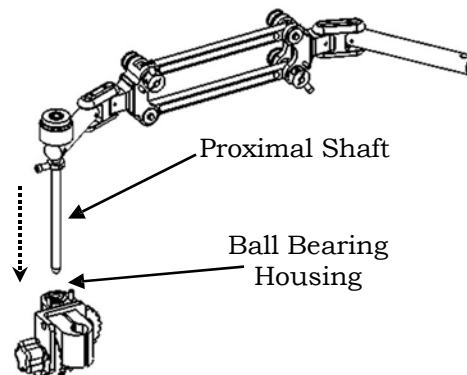

- Insure that the Stem Collar (pictured on page 2-2) is on the Swivel Stem. Insert Swivel Stem into the 1/4" hole of Distal Arm.

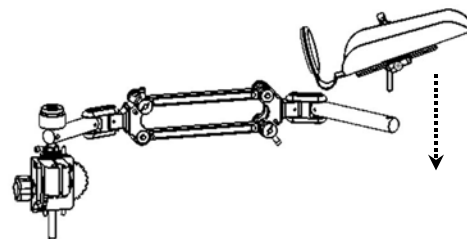

- Standing in front of the wheelchair, the Multilink Mobile Arm Support should resemble the picture to the right.

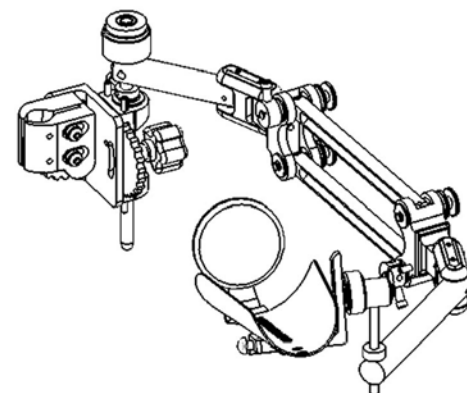

- When optimum adjustments have been made (refer to page 7-1) Secure the settings.

# **Section 5**

## **Basic Adjustments for the Elevation Assist**

# Adjustable Parts Description

MultiLinks with Elevation Assist are equipped with an up and down elevation stop.

Note the descriptions below then proceed to next page.

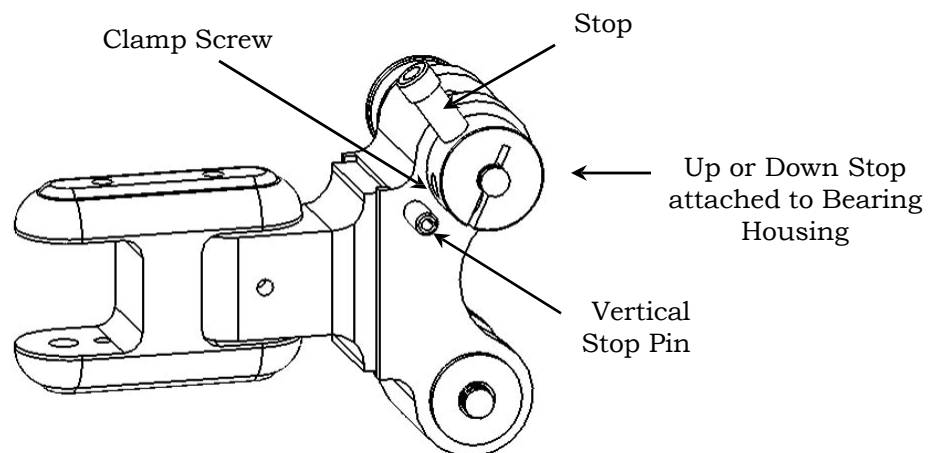
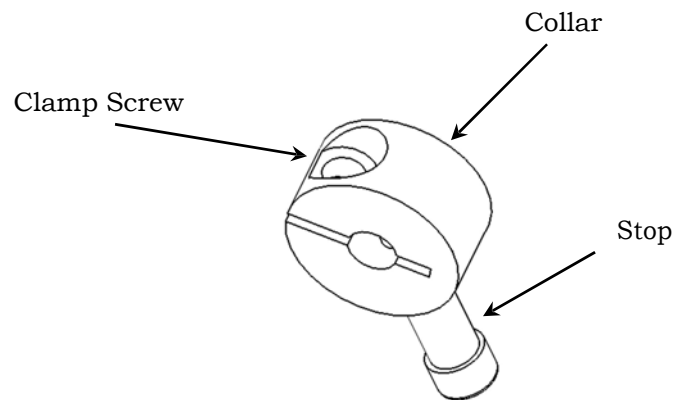

## Adjusting Down Elevation Right Side



Down Elevated Functional Limit

1. Rubber Bands should not be attached when setting stops.
2. While supporting the patient's limb in the lower functional position, loosen the Clamp Screw on the Down Stop Collar using large T-Wrench, rotate the Collar counter clockwise until the Stop rests against the lower side of the Vertical Stop Pin. (see photo to the right)
3. Insert large T-Wrench into the Clamp Screw, then turn clockwise securing the Down Stop in place.

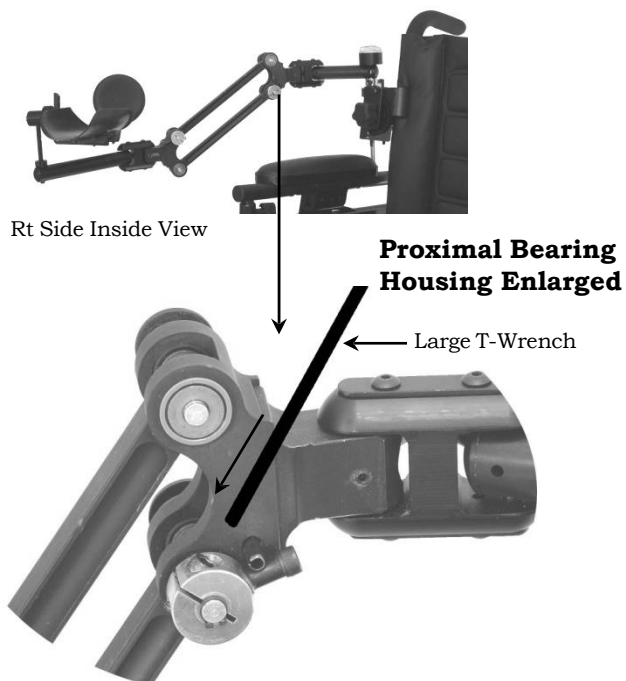

**Note:** To adjust the position of the Proximal Shaft Collar tighten or loosen the Clamp Screw.

## Adjusting Up Elevation Right Side



Up Elevated Functional Limit

1. Rubber Bands should not be attached when setting stops.
2. While supporting the patient's limb in the elevated functional position, loosen the Clamp Screw on the Up Stop Collar using large T-Wrench, rotate the Collar clockwise until the Stop rests against the lower side of the Vertical Stop Pin. (see photo to the right)
3. Insert large T-Wrench into the Clamp Screw, then turn clockwise securing the Down Stop in place.

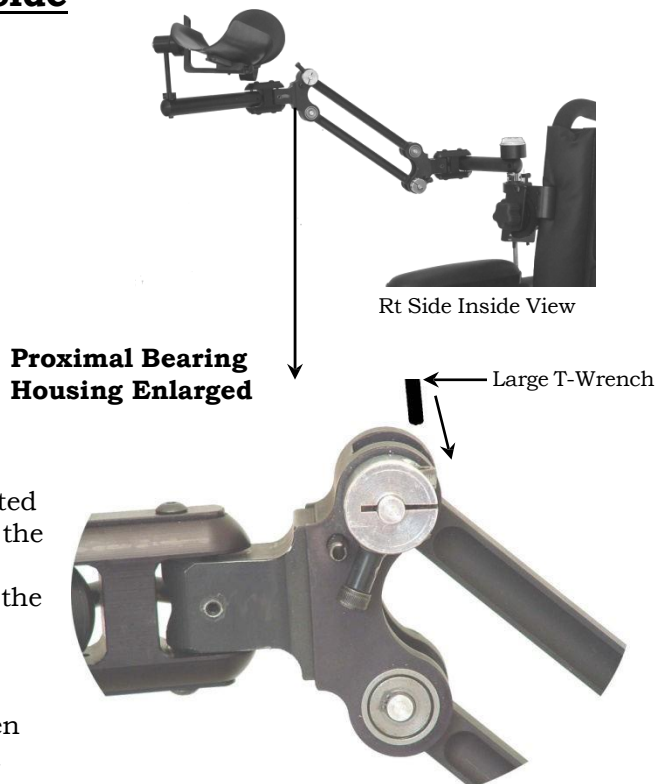

**Note:** To adjust the position of the Proximal Shaft Collar tighten or loosen the Clamp Screw.

## **Adjusting Down Elevation Left Side**



Lower Functional Limit

1. Rubber Bands should not be attached when setting stops.
2. While supporting the patient's limb in the lower functional position, loosen the Clamp Screw on the Down Stop Collar using large T-Wrench, rotate the Collar clockwise until the Stop rests against the upper side of the Vertical Stop Pin. (see photo to the right)
3. Insert large T-Wrench into the Clamp Screw, then turn clockwise securing the Down Stop in place.



Left Side Inside View

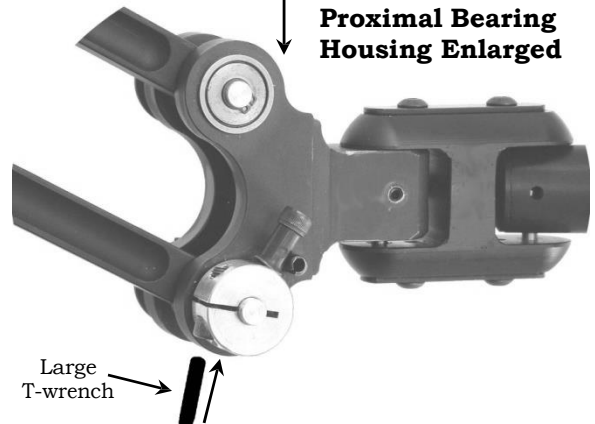

**Proximal Bearing Housing Enlarged**

Large T-wrench

**Note:** To adjust the position of the Proximal Shaft Collar tighten or loosen the Clamp Screw.

## **Adjusting Up Elevation Left Side**



Elevated Functional Limit

1. Rubber Bands should not be attached when setting stops.
2. While supporting the patient's limb in the elevated functional position, loosen the Clamp Screw on the Down Stop Collar using large T-Wrench, rotate the Collar counter clockwise until the Stop rests against the upper side of the Vertical Stop Pin. (see photo to the right)
3. Insert large T-Wrench into the Clamp Screw, then turn clockwise securing the Down Stop in place.



Lt Side Inside View

**Proximal Bearing Housing Enlarged**

Large T-wrench

**Note:** To adjust the position of the Proximal Shaft Collar tighten or loosen the Clamp Screw.

## MultiLink with Elevation Assist Rubber Band Setup

With Up/Down Stop adjustment completed attach the rubber bands as shown in the pictures below. The rubber bands will be layered upon each other.

**Note:** *The weight and muscle tone of the patient's limb will determine the number of rubber bands required to obtain optimum function. Rubber bands supplied contain Dry Natural Rubber.*

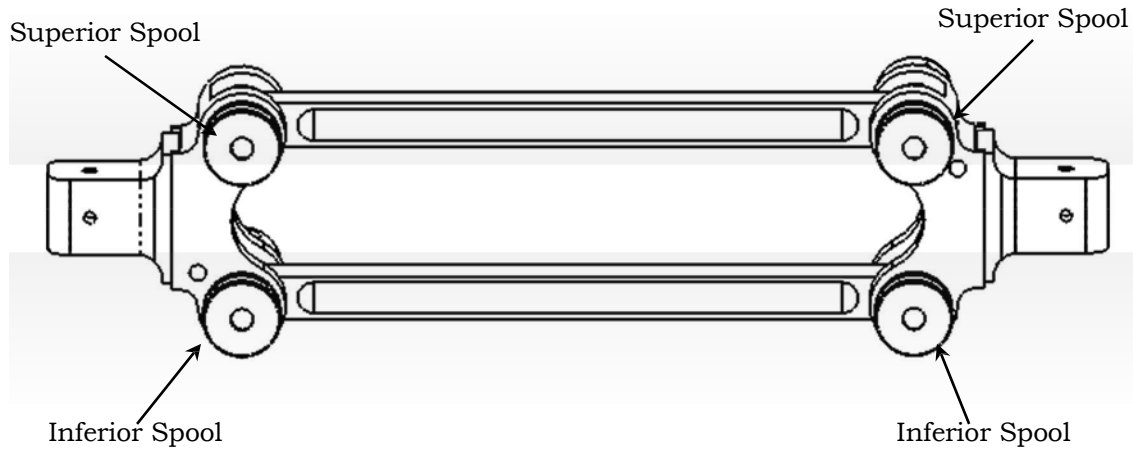

**Note:** *These setup instructions are to be used for both Left and Right rubber band attachment. The photo's are of the right outside view. Left side view will look just the opposite.*



1. Hook rubber band into the tracks of the Distal and Proximal Inferior Spools.



2. Pinch rubber band and hook into track of Proximal Superior Spool



3. Add more rubber bands as needed to obtain optimum balance.

**Refer to Section 6 for Basic Adjustments to anterior/posterior and medial/lateral functions**

# **Section 6**

## **Basic Adjustments for Functional Use of the MultiLink MAS**

## Recommendation:

Develop an initial comfort level making scroll wheel adjustments without an arm in the MAS.

- With the MultiLink MAS System attached to the wheelchair, loosen both Lock Knobs A and B just enough to easily turn Scroll Wheel A and Scroll Wheel B. Turn Scroll Wheels A and B separately and also simultaneously.
- Observe how the adjustments affect the movement of the MAS.
- Return the Mount to neutral balance using the Bubble Level.

**Note:** *Turning the Scroll Wheels tilt the MAS to help the person move in the direction that he/she is weaker. The person must have enough strength to move against the assisted motion.*

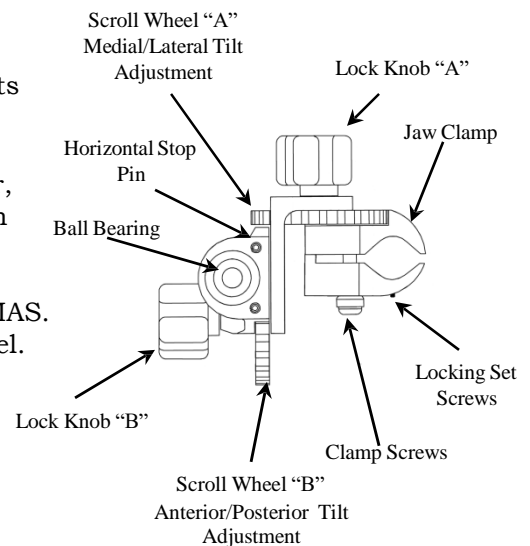

## Horizontal Movements:

### Medial/Lateral (side to side) Movements (use Scroll Wheel A):

1. With the person's arm in the MAS, **passively move** his/her arm as far as possible across the body and then out to the side. This defines the maximum medial-lateral reach area.
2. Ask the person to **actively move** his/her arm as far as possible from side to side.
3. **Observe active movements.** Is motion in one direction greater or easier than the other? Consider the work area needed for task performance as you evaluate his/her range of movement.
4. **Adjust for side to side reach.** Loosen Lock Knob A and turn Scroll Wheel A in small increments in the direction you want to increase movement. (see photos on the right)

**Note:** *The weight of the person's arm must be supported under the forearm support in order to turn the scroll wheels.*



Mount tilted to assist reach across the body. Exaggerated for effect.

5. After each adjustment, ask the person to move his/her arm from side to side and re-adjust until you have the optimum range of movement for his/her needs. **Repeated adjustments** may be needed during the fitting process. Tighten the Lock Knob to secure the Scroll Wheel after each adjustment.



Mount tilted to assist reach to the side. Exaggerated for effect.

## **Anterior/Posterior or Forward Reach/Return Movements (Use Scroll Wheel B):**

- Repeat previous steps #1-5 (page 5-1) but for forward reach and return motions, using **Scroll Wheel “B”**.
- Adjustments made for one movement may affect the other.
- Repeat as necessary with both **Scroll Wheels A and B** to obtain the best adjustment for the person’s functional needs.
- The goal is to achieve overall optimal functional range.
- Readjustments may be needed.

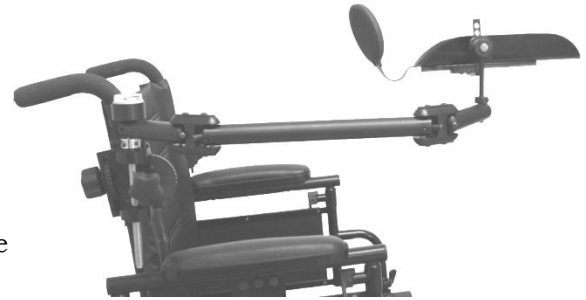

Scroll wheel B tilted to aid forward reach (exaggerated for effect)

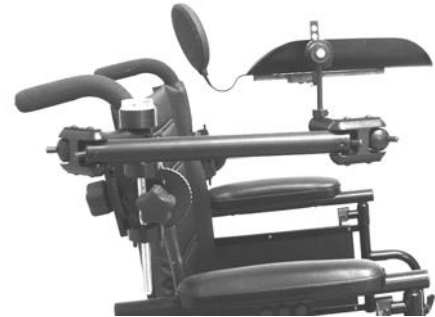

Scroll wheel B tilted to aid return motion (exaggerated for effect).

### **Check for clearance:**

Does the stem of the Offset Swivel hit the wheelchair armrest and/or tabletop?

- If this is a problem, the forearm support may need to be raised.
- **To Raise Forearm Support:**  
(Refer to page 2-1 for part descriptions)
  1. Insert small T-wrench into clamp screw on Stem Collar and rotate counter clockwise to loosen.
  2. Slide Stem Collar down the Swivel Stem to obtain optimum clearance.
  3. Insert small T-wrench into clamp screw on Stem Collar and rotate clockwise to tighten.
- The alternative suspension setup may be necessary. (see photo on right)  
Refer to the "Special Circumstances and Alternatives" (page 8-3) for setup instructions.
- It may be necessary to re-adjust the height of the Mount. Refer to the "Special Circumstances and Alternatives" (page 8-2) if problems are encountered.

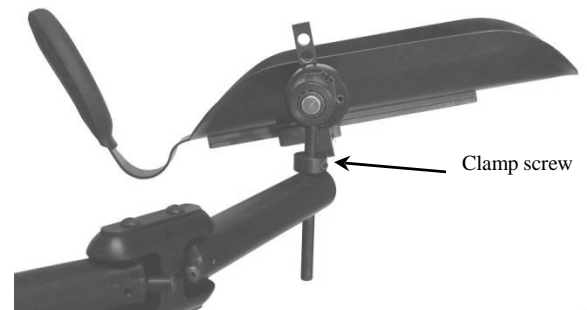

## Use of the Proximal Shaft Collar:

- The Proximal Shaft Collar must always be used.
- The Proximal Shaft Collar can be used to limit the lateral arm movement, especially if the MultiLink swings out to the side and the person cannot bring it back to the midline work area and to raise the height of the MultiLink Arm if needed.

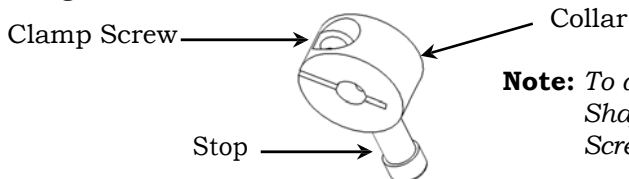

**Note:** To adjust the position of the Proximal Shaft Collar tighten or loosen the Clamp Screw.

### How to use the Proximal Shaft Collar as a lateral stop:

(read each step)

1. Insure that the set screw on the proximal arm of the MultiLink is tightened so that it is securely attached to the Proximal Shaft.
2. **Loosen** the Clamp Screw on the Proximal Shaft Collar to allow it to rotate freely on the Proximal Shaft
3. Ask the person to actively move his/her arm as far to the side as possible while still being able to bring it back to the center. (If the lateral movement needs to be restricted, the lateral stop function is needed.)
4. To set the lateral stop function, hold the proximal arm of the MultiLink at the end range of the desired lateral movement.
5. Move the Proximal Shaft Collar so that the Stop rests against the back Horizontal Stop Pin on the mount at this established end range. (see photo at right)
6. Tighten the Clamp Screw on the Proximal Shaft Collar in this position.
7. Check the Stop position by asking the person to move his/her arm to the side. The person should be able to return arm to the midline work area.

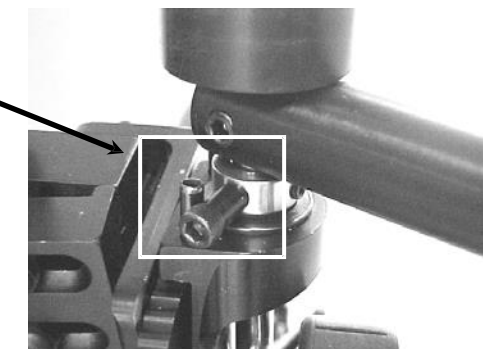
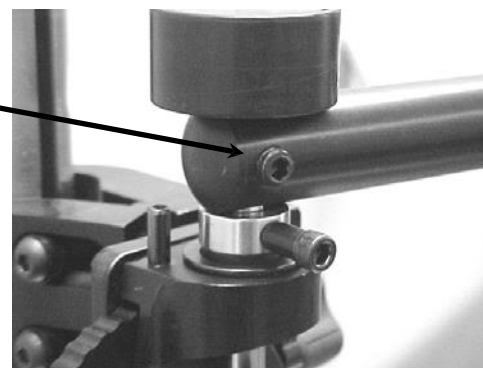

### **Note: If the lateral stop function is not needed:**

- The Proximal Shaft Collar must still be used whether the lateral stop function is needed or not; the Collar allows the proximal arm to clear the Mount's Horizontal Stop Pins.
- Tighten the Collar Clamp Screw with the Stop directly under the proximal arm so it does not hit the Horizontal Stop Pin on the mount and interfere with the horizontal motions. (see photo)
- The proximal arm can now be fully retracted, and it is easier to move through doorways. (see photo)

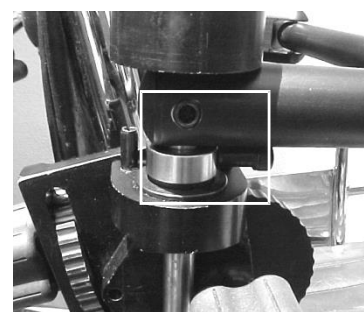

## Document the Functional Working Range:

- It may help to mark these horizontal tabletop ranges for future reference and comparisons.
- Different colored marking pens can be used to record differences in range with and without the MAS or with different settings of the MAS.
- Indicate body midline with an “X” and use a dotted line for orientation of the paper for reference and comparisons.

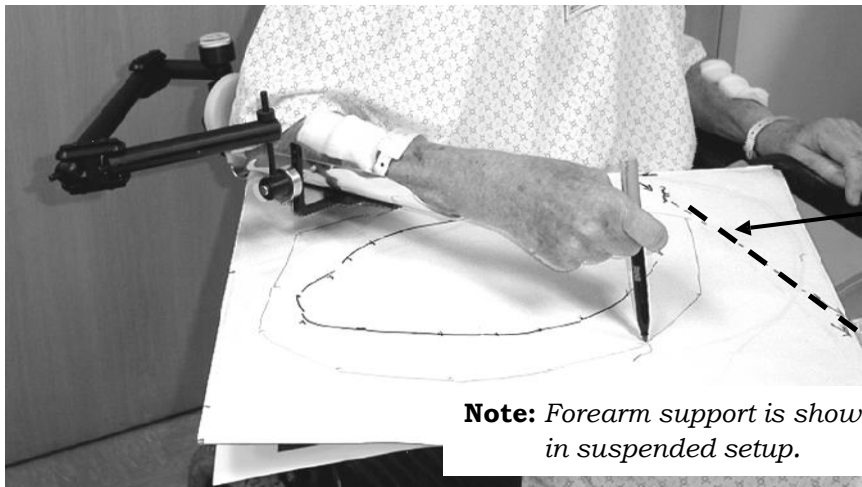

This dotted line indicates Body Midline

## Vertical Movements:

Check Alignment of the Offset Swivel Pin. Change position **only** if needed. In most cases, the manufacturer's setting will be adequate.

- Note the recommended position of the Offset Swivel Pivot Pin in the photo on the right. Movement is easier if the Pivot Pin is slightly lower rather than higher than this mid-position. This mid-position usually allows easy pivoting motions without excess shoulder hiking.

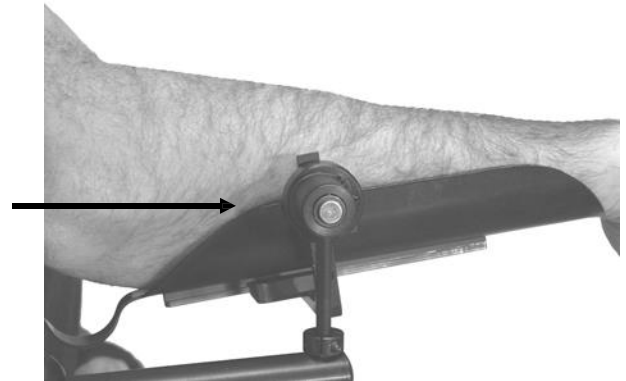

- If the position of the Pivot Pin needs to be changed:
  - Remove the Forearm Support assembly from the MultiLink.
  - Detach the offset swivel from the L-bar. (Firmly hold the L-bar and press out the pin with your thumb(s). If difficult, remove the forearm support from the L-bar (remember to loosen the distal screw to slide off). Stabilize the inside pivot pin against a flat stable surface and press down on the L-bar. (see photos below).
  - Reattach the pin in the desired hole by firmly pressing pin into the hole. The Pivot Pin must be inserted all the way through.

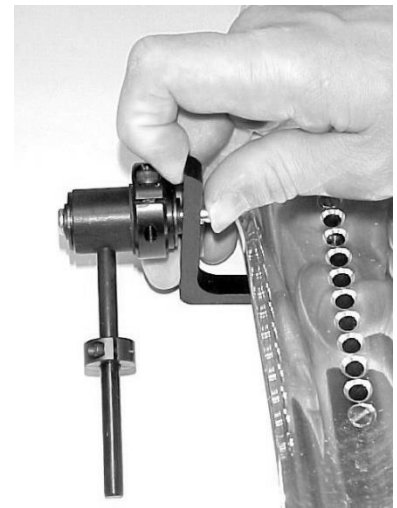

Note: The Down Stop should be on the front side of the L-bar for Right side setup and rear of the L-bar for Left side setup. Refer to page 5-7



Pressing out pivot pin with thumbs.

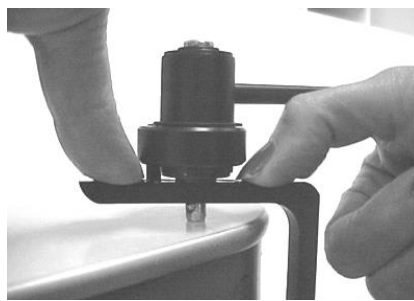

Pressing out pivot pin against table surface.

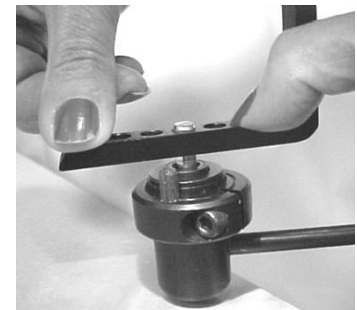

Reattaching L-bar with Down Stop in front.

## Hand to Mouth Movements:

1. With the person's arm in the Forearm Support, **passively move** the person's hand from tabletop to his/her mouth.
  - Can hand reach the mouth?
  - Does the elbow dial hit the laptop or tabletop? (review "check for clearance" page 5-2)
  - Is the person's elbow centered on the elbow dial when hand is near the mouth?  
Bend the elbow dial as necessary to center the elbow
2. Ask the person to **actively** bring his/her hand to their mouth. If he/she has difficulty, instruct the person to push down with his/her shoulder or to move their elbow down and inward toward their body. This causes the elbow to push down on the elbow dial and brings the hand to the mouth. Ask the person to relax the shoulder to bring the hand down to the tabletop.
3. Determine which motion is more difficult.
4. Adjust the Slide to Assist Hand to Mouth Movements:

**Note:** *During functional adjustments, it is not necessary to remove the person's arm from the forearm support. Bend the person's elbow so full arm weight is not on the slide mechanism, but on the elbow dial. Support the weight of the person's forearm with one hand under the elbow dial; move the adjustable slide with the other hand.*

- Assist hand to mouth motions by moving the Adjustable Slide. (see photos below).
- Moving the slide toward the wrist usually aids the "up" motion.
- Moving the slide toward the elbow usually aids the "down" motion.



Slide positioned so forearm support is balanced.



Slide moved forward to aid the up motion. (exaggerated for effect)



Slide moved back toward elbow to aid the down motion. (exaggerated for effect)

5. Set the Down Stop: The Down Stop limits the downward motion and makes it easier for the person to bring their hand back “up” to their mouth.
  - Loosen (do not remove) the Clamp Screw on the Down Stop Collar using the large T-Wrench to allow pivotal movement of the offset swivel. (Refer to page 2-1)
  - **Note:** *The Down Stop should not hit against the L-bar during “up” motions.*
  - If the Down Stop function is needed to limit the down motion:
    1. Position the forearm support in the maximum down position desired.
    2. Rotate the Collar until the Down Stop rests against the L-bar and blocks further downward motion, see photos below. (The Down Stop will hit the L-bar on the top/front for the Right side setup and bottom/rear for Left side setup.)
    3. Tighten the Clamp Screw in this position to set the “stop” function.

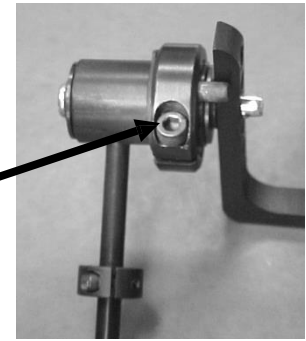

Offset Swivel Assembly,  
Right Side



Right side (close up, inside): Down Stop rests against the top/front of the L-bar to limit the “down” motion



Offset Swivel Assembly,  
Left Side



Left side (close up, inside): Down Stop rests against the bottom/rear of the L-bar to limit the “down” motion

6. Raise the Forearm Support, as needed. It may be necessary to raise the forearm support by moving the stem collar to a lower position. (Refer to page 5-2) **To Raise Forearm Support.**



# **Section 7 Finalizing Setup**

## Check Overall Setup

- Again, observe the person's shoulders to be sure they are at a comfortable, level, resting position. (If the person is uncomfortable, MAS wear time and use will be limited.)
- Make re-adjustments as necessary to achieve normal shoulder height. (It may be necessary to lower the mount placement.)
- Refer to the "Special Circumstances and Alternatives" section if mount placement is a problem.

## Secure the Settings

After evaluating the MAS use with a variety of functional activities, and when you are satisfied with the adjustments, secure the settings.

- Using the small T-Wrench tighten the Locking Set Screws on the MAS Mount to secure it to the wheelchair upright. The pointed end of these lock screws will pierce fabric and/or metal.
- Insure all knobs and screws are tight.

## Locking the Mount in Place

When optimal functional use of the mobile arm support is achieved, tighten the **Locking Set Screws** using the small T-Wrench. This will lock the mount in its position on the wheelchair upright (back post).

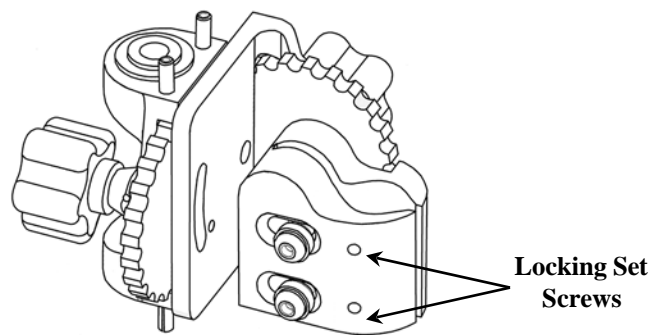

## Mark the Settings

- Mark the settings when you are satisfied with the adjustments. Mark scroll wheels, mount position, stem position, etc. See photos below. When marked, it is easy to match up the marks and return to your desired settings if parts get out of alignment or moved.
- Correction fluid works well on the black for initial adjustments because it can be removed with a damp cloth. Nail polish can be used for a more permanent marking. Different settings might be desired for varied activities such as keyboard activity or feeding; markings can be color coded.

Marks on the W/C upright and also on the mount make it easy to realign the pieces, if moved.

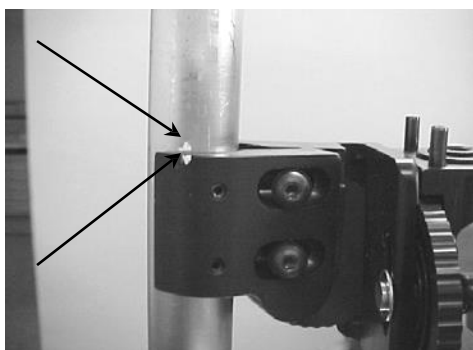

Line markings on the forearm support or stem make it easy to find the correct Position for various activities

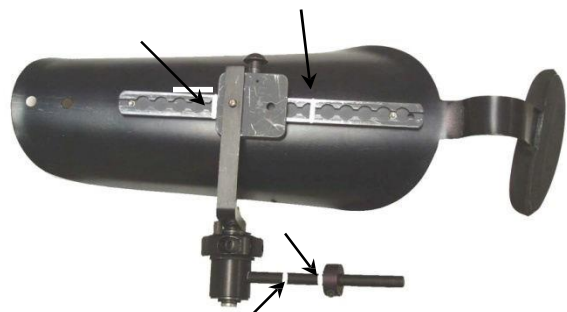

## HOW TO REMOVE THE MAS FOR TRANSPORT:

- Lift the Offset Swivel stem up and out of the distal link.
- Lift the Proximal Shaft up and out of the Mount. (leave MultiLink attached to the shaft)
- Place the MAS parts in a protective bag to protect the black anodized covering from scratches.
- Leave the Mount on the wheelchair.

# **Section 8 Special Circumstances and Alternatives**

## MAS Mount Attachment Problems:

### Alternative Mount Attachment:

Invert the mount (turn it over). Clamp Screws face toward the back of wheelchair and Lock Knob A faces front. Clamp Screws are easier to reach for tightening and adjusting in this position.

### View from Above

#### LEFT Side

(Front of wheelchair)

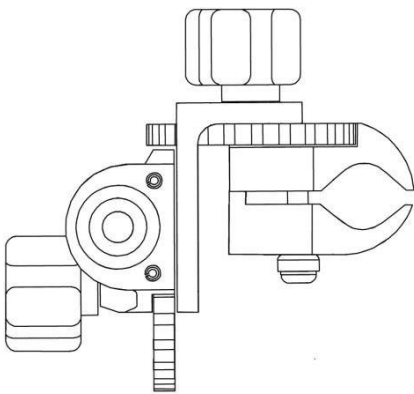

(Back of wheelchair)

#### RIGHT Side

(Front of wheelchair)

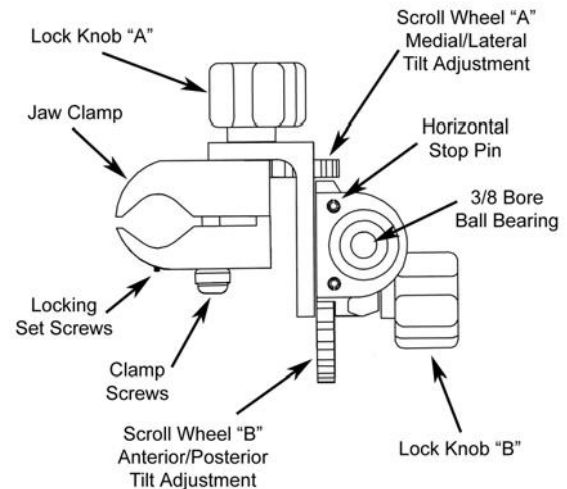

(Back of wheelchair)

Depending upon location of the mount attachment, Lock Knob "A" might cause pressure against the back of the person's upper arm when their forearm is resting on the wheelchair armrest and not in the MAS. (See photo on right). If this occurs, do not use this setup.



Alternative Mount Setup

- If this happens, **use the regular Mount setup** with the Lock Knob "A" facing to the back and the Clamp Screws facing the front. This should make it more comfortable for the person when not using the MAS.

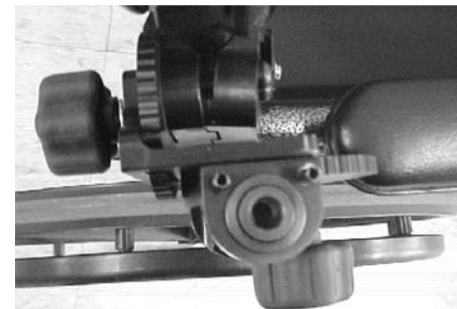

Regular Mount Setup

Unit 163 - 5489 Byrne Road  
Burnaby, BC. V5J 3J1 Canada

- If the Mount still rests against the upper arm, it **can be mounted at an angle**. Scroll Wheel “A” will no longer be just for Side to Side adjustments, and Scroll Wheel “B” will no longer be just for Forward/Return adjustments. Combined Scroll Wheels A and B adjustments will be necessary.

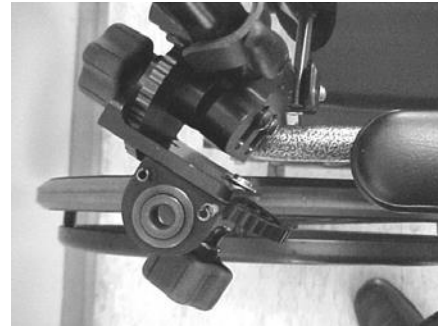

**If the Proximal Shaft hits the W/C armrest and cannot be fully inserted:**

- Attach the mount at an angle as described above.

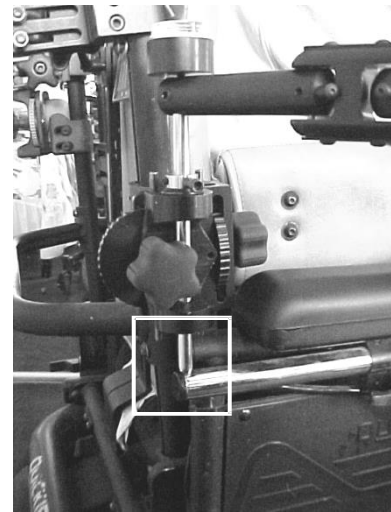

**If the mount is too low:**

- The **MultiLink Arm can be raised slightly** and secured by lowering the Proximal Shaft Collar on the Proximal Shaft and re-tightening the Clamp Screw. Insure the Set Screw on the proximal arm is tightened to secure the MultiLink to the Proximal Shaft. (This modification is not recommended for those with heavy arms or increased tone because of the added stress on the shaft and mount.) The shaft must protrude through the bottom ball bearing on the mount.



- The person’s arm can be raised to compensate for a low placed mount by **elevating the forearm support**. Lower the Stem Collar on the Swivel Stem as shown in the photo and tighten the Clamp Screw.



- **If the mount is too high** and can only be mounted above the person's mid-humeral level, the Forearm Support may need to be lowered by suspending the Forearm Support.

## **Suspending Forearm Support:**

- Insert the Swivel Stem of the Offset Swivel from the bottom up and secure with the Stem Collar on top. If this setup is used, **do not** constantly remove the Stem Collar. It is recommended that the MAS system be kept as one unit if removed from the mount for storage or transport. As one unit, the MAS is less compact for fitting in a wheelchair backpack for transport but easier for setup.



## **If the mount cannot be attached with the Scroll Wheel “A” in line with the W/C armrest:**

It is possible to attach the Mount at an angle. Combined adjustments of the Scroll Wheels A and B will allow for medial/lateral and anterior/posterior movements.

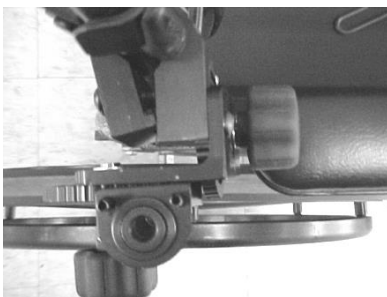

Scroll Wheel A in line with the WC armrest  
(top view)

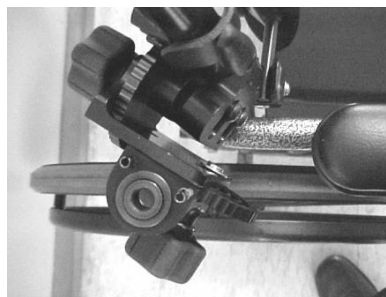

Mount attached at an angle  
(top view)



Mount attached at an angle  
(front view)

**When the shape of the wheelchair upright, its position or obstructions from other equipment attached to the upright do not allow for optimal mount positioning a Mount Relocator (section 9) should be used.**

## Problems with Clearance of Swivel Stem or Elbow Dial:

- **Raise the forearm support** by lowering the Stem Collar on the offset Swivel Stem and tightening the Clamp Screw.



- **Move the adjustable slide** under the forearm support back 1 to 2 notches toward the elbow. This will only work if the person can still easily move their hand up and down after the adjustment.



- **Try the alternative Suspension Set-up:**

1. Remove the Stem Collar on the Offset Swivel.
2. Insert the Offset Swivel Stem from bottom up.
3. Secure with the Stem Collar on the top.
4. Raise the Mount or MAS.
5. Readjust MAS as needed for optimum patient functioning.



Funded by

National Institute for Disability & Rehabilitation Research  
(NIDRR Grant #H133E003001)

Developed by

Rehabilitation Engineering Research Center on Technology  
for Children with Orthopedic Disabilities  
Rancho Los Amigos National Rehabilitation Center

# Application and Adjustment for the Manual Arm-Height Adjustor

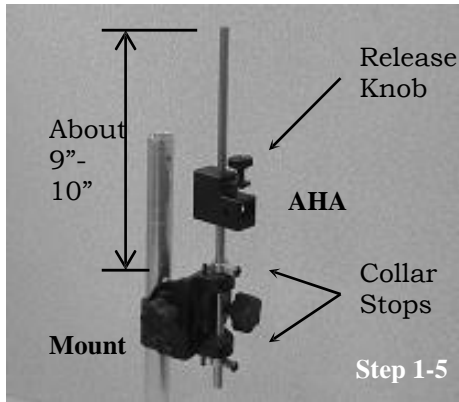

- Attach the mount to the wheelchair (WC), and unscrew the bubble level from the 14" rod.
- Place the rod into the ball bearings of the mount such that a collar stop can be attached to it below the mount. It is suggested that nine to ten inches of the rod should protrude above the mount.
- Secure the rod in place using two collar stops; one is placed just above the mount and one is placed just below.

- Turn the release knob on the arm-height adjustor (AHA) counter-clockwise until resistance is met. Press the release knob down with the thumb, and hold it down.
- Slide the arm-height adjustor onto the 14" rod with the release knob on top. The arm-height adjustor will self lock when the knob is released.
- Orient the multilink arm to the desired side (R-L), and remove the 5/16" set screw at the proximal/lateral end of the arm.



- Insert the proximal end of the multilink arm into the arm-height adjustor.
- Align the holes on the sides of the multilink arm with the corresponding holes on the arm-height adjustor. Place the flanged button-head screw (provided) into the lateral hole and tighten it completely. (Note: The first time this screw is tightened all the way, resistance may be felt)

- The height of the multilink arm can be adjusted in either direction while the release knob is pressed down. (Note: Hold the arm-height adjustor with the fingers underneath and thumb on top. The other hand provides distal support)

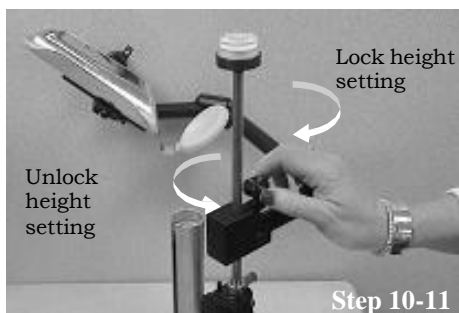

- Turn the release knob clockwise until it is tight. This secures the multilink arm to the rod, preventing it from moving vertically or rotating on the rod. It also serves as an additional safety lock. (Note: The release knob must be turned counter-clockwise in order to make vertical adjustments or remove the device from the rod)

- Screw the bubble level back into the top of the rod, or place a soft ball over it for safety.

# **Section 9**

## ***JAECO***

# **Mount Relocators**

# Mount Relocator

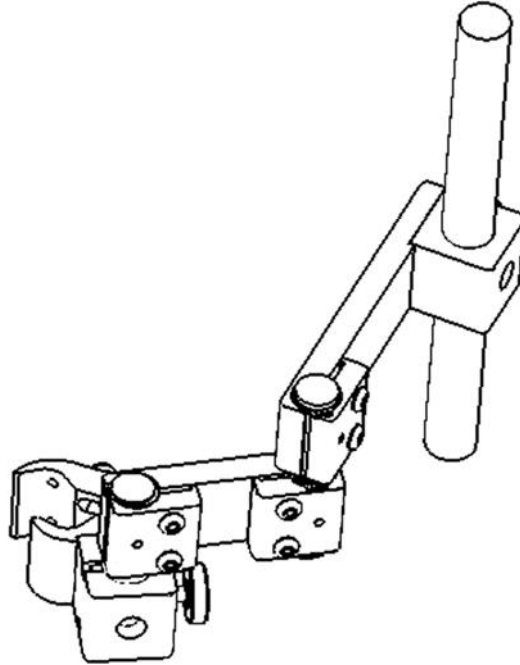

## For Mounting to Wheelchairs with Tubular Back Posts

### Features:

- The unique design of the Mount Relocator has several advantages over our previous Bracket Relocator.
- The new Mount Relocator clamps onto  $\frac{3}{4}$  inch to 1 inch tubing.
- Clamps over back posts (wheelchair uprights) enclosed in fabric without having to remove the fabric from the mounting area.
- The 10 inch long mounting shaft and articulated arms of the Mount Relocator allow for optimum Mobile Arm Support mount position.
- The Clamp Mount Base requires only 1.5 inches to mount to the wheelchair back post (wheelchair upright).
- The solid anodized black aluminum construction minimizes deflection.
- This Mount Relocator even with the Mobile Arm Support attached can be removed and replaced quickly by the turn of a knob, without losing it's preset adjustments.

## Standard Setup

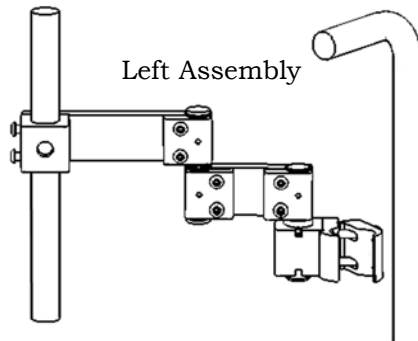

Left Assembly

Viewed from back side of wheelchair

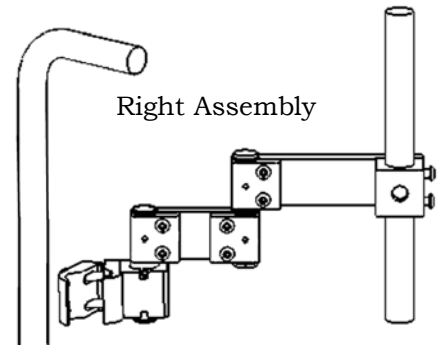

Right Assembly

## Alternate Setup

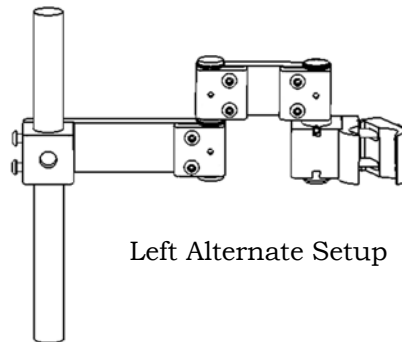

Left Alternate Setup

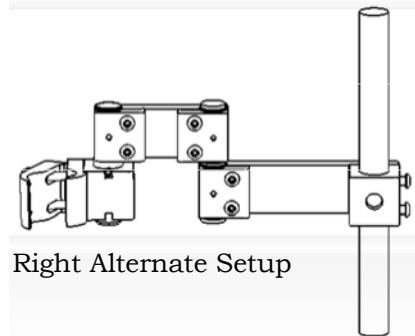

Right Alternate Setup

## Preparation

1. Locate and mark on the back post (wheelchair upright) the patient's mid humeral area.

**Note:** The mount base needs to be attached a minimum of approximately 5 inches above or 8 inches below this mid humeral location. Alternate arm setup will decrease the amount of clearance needed when attached above marked location.  
See Alternate Setup images above.

2. If the relocater Mount Base is attached to the Mount Relocator, loosen Locking Knob and remove the Mount Base.
3. Loosen, **Do not remove**, Clamp Screws using large T-Wrench. Push floating clamp forward and outward.

Mount Base

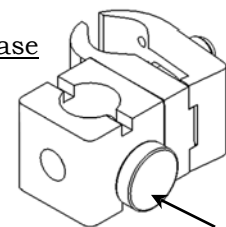

Locking Knob

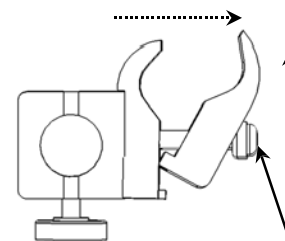

Clamp Screws

## Mounting

1. Attach relocater Mount Base to location on back post (W/C upright) as specified in Preparation Instructions page 9-2 and tighten Clamp Screws just enough so it is snug but will still rotate on the back post. This rotation may be necessary for relocater arm alignment.

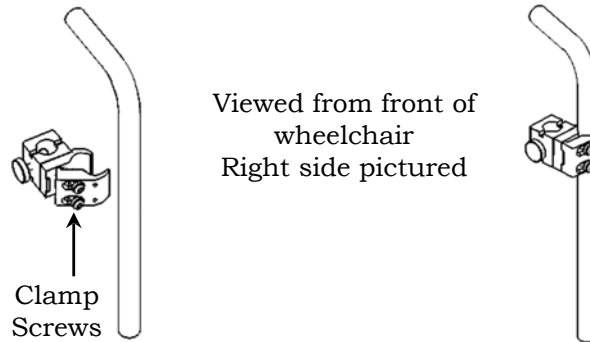

2. Loosen, **Do Not Remove**, all six Clamp Screws on relocater arm. Insert the Mount Relocator into the Mount Base and insure the Pin in the Arm Shaft inserts into the Slot on the top of the Mount Base then tighten Locking Knob.

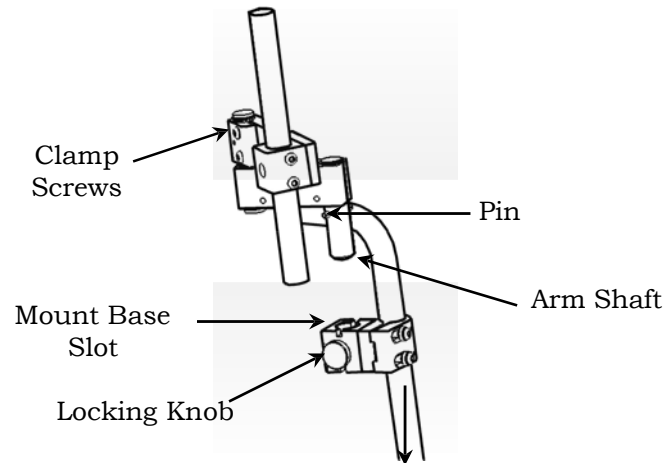

## Finalizing Setup

1. Align the Mount Shaft with patient's back by adjusting the Relocator arms.
2. Attach the Mobile Arm Support mount (bracket) to the Mount Shaft and align the top bearing of the mount with the mid humeral location of the patient's arm.
3. When optimum position is acquired tighten all **eight** Clamp Screws using large T-Wrench.
4. When final mount (bracket) position is obtained then tighten all **five** Locking Set Screws using small T-Wrench to secure relocators position.

**Note:** *It is recommended that the Locking Set Screws only be used once, when all adjustments are completed. Tightening and readjusting these screws can cause damage to the Relocator Arm Pin.*

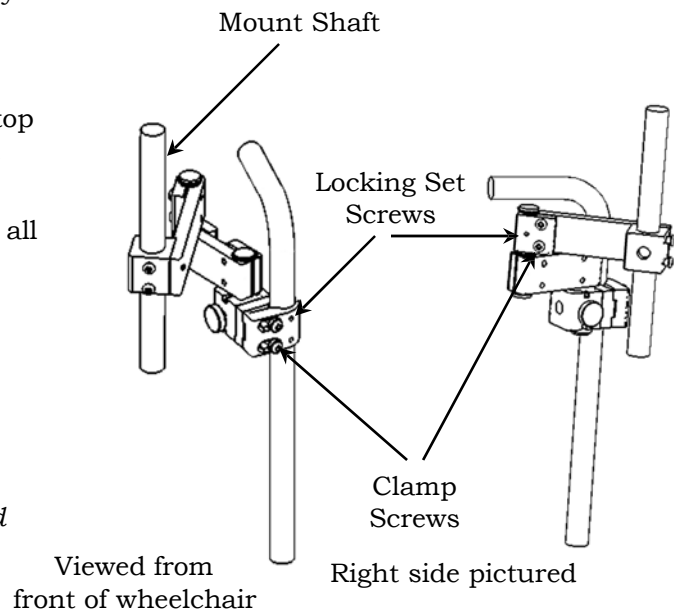

# Mount Relocator

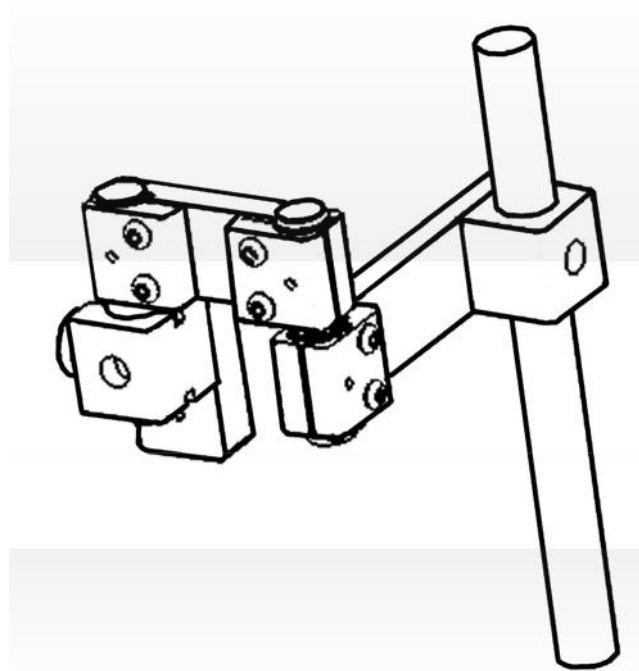

## **For Mounting to Wheelchairs with Molded Back Rests when back posts are restricted or not present**

### **Features:**

- The unique design of this Mount Relocator is that it can attach to plastic or metal wheelchair backrests when back posts are restricted or not present.
- The 10 inch long mounting shaft and articulated arms of the Mount Relocator allow for optimum Mobile Arm Support mount position.
- The Mount Base requires only 3 inches to mount to the wheelchair backrest.
- The solid anodized black aluminum construction minimizes deflection.
- This Mount Relocator, even with Mobile Arm Support attached, can be removed and replaced quickly by the turn of a knob, without losing it's preset adjustments.

## Standard Setup

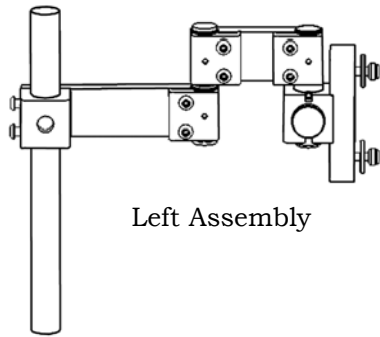

Left Assembly

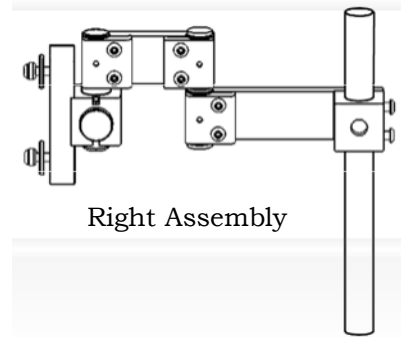

Right Assembly

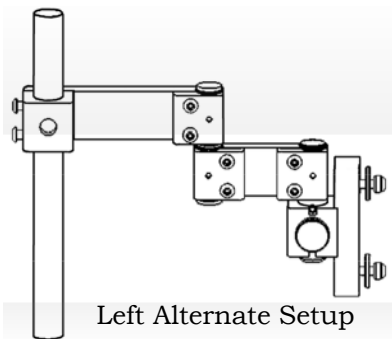

Left Alternate Setup

## Alternate Setup

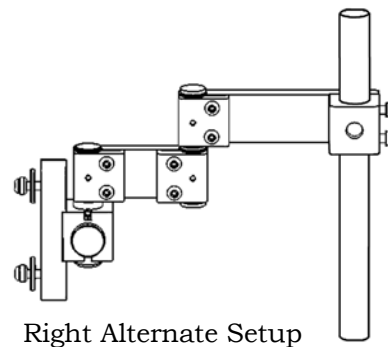

Right Alternate Setup

## Preparation

1. If the relocater Mount Base is attached to the Mount Relocator, loosen Locking Knob and remove the Mount Base.
2. Remove the two Attachment Screws and Reinforcement Washer from the Mount Base
3. Remove backrest cushion .
4. Place template on back of backrest 1.5 to 2 inches down from inner edge and over 2.5 inches from outside edge and mark template holes.

**Note:** Place Base Drill Template on flattest area of backrest

5. Use drill bit supplied and drill the two marked holes.

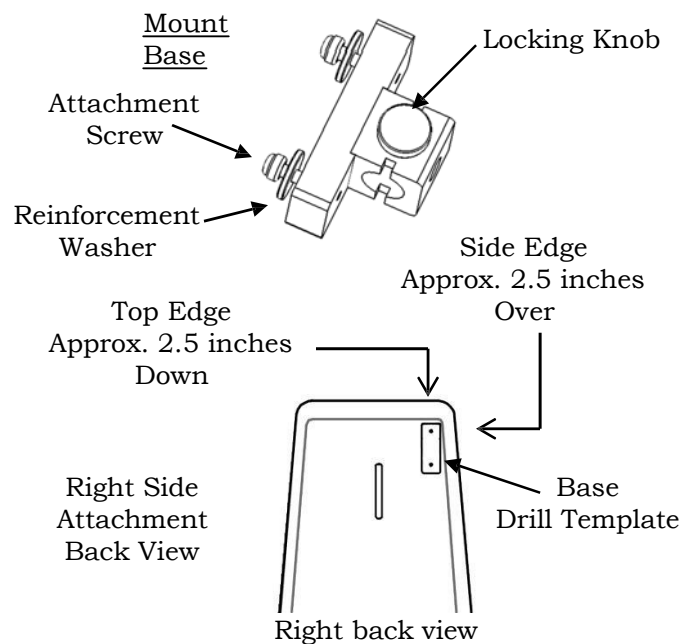

## Mounting

1. Insert Screw and washer through hole on cushion side of backrest and use large T-Wrench to tighten into Mount Base.

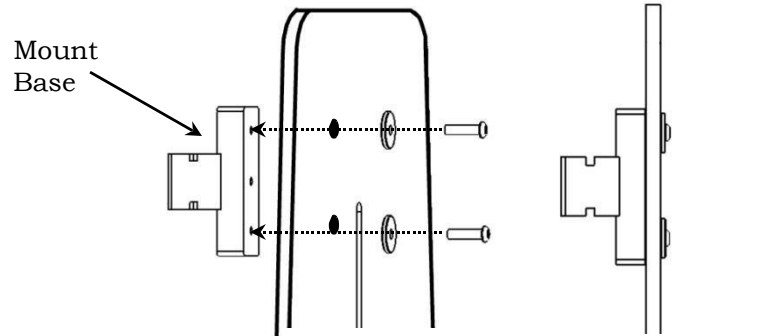

2. Loosen, **Do Not Remove**, all six Clamp Screws on relocater arm. Insert the Mount Relocator into the Mount Base and insure the Pin in the Arm Shaft inserts into the Slot on the top of the Mount Base then tighten Locking Knob.

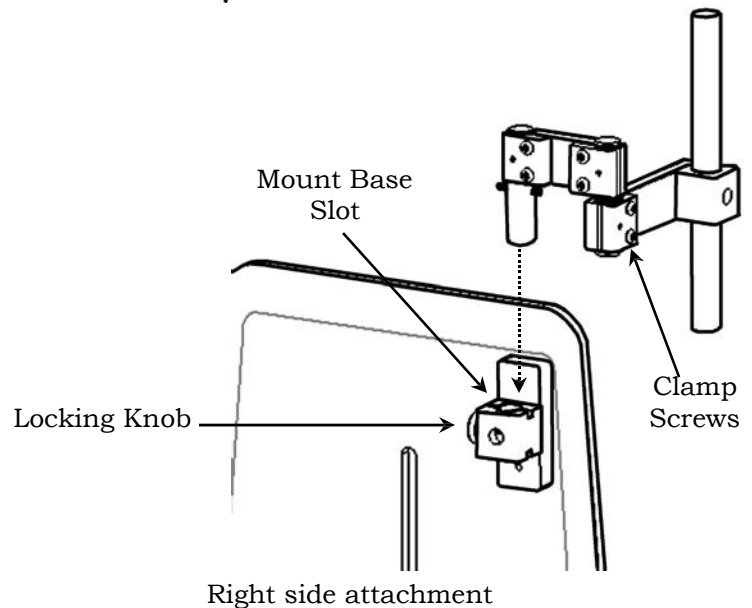

## Finalizing Setup

1. Align the Mount Shaft with patient's back by adjusting the relocater arms.

**Note:** Alternate arm setup will increase Mount shaft height if needed. See Alternate Setup Page 9-5.

2. Attach the Mobile Arm Support mount (bracket) to the Mount Shaft and align the top bearing of the mount with the mid humeral location of the patient's arm.
3. When optimum position is acquired tighten all **six** Clamp Screws using large T-Wrench.
4. When final mount (bracket) position is obtained then tighten all **three** Locking Set Screws using small T-Wrench to secure relocators position.

**Note:** It is recommended that the Locking Set Screws only be used once, when all adjustments are completed. Tightening and readjusting these screws can cause damage to the Relocator Arm Pin.

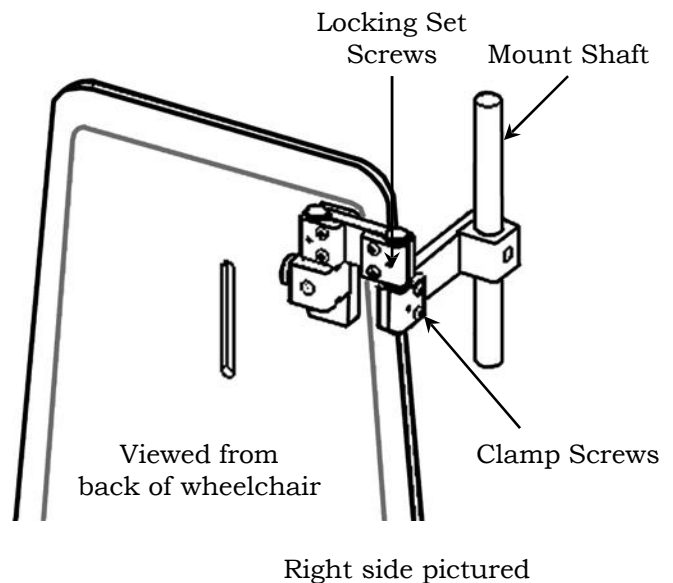

# Mount Relocator

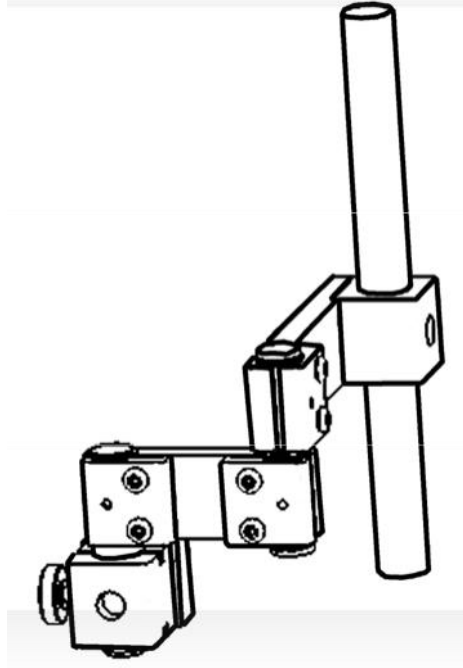

## For Mounting to Wheelchairs with Keyed Back Posts

### Features:

- The unique design of the Mount Relocator has several advantages over our previous Bracket Relocator.
- This Mount Relocator attaches to Keyed Back Canes (W/C upright) for some Invacare, Motion Concepts and other seating systems.
- The 10 inch long mounting shaft and articulated arms of the Mount Relocator allow for optimum MAS mount position.
- The Mount Base requires only 1.5 inches to mount to the Keyed Back Cane.
- The solid anodized black aluminum construction minimizes deflection.
- This Mount Relocator, even with the Mobile Arm Support attached, can be removed and replaced quickly by the turn of a knob, without losing it's preset adjustments.

## Standard Setup

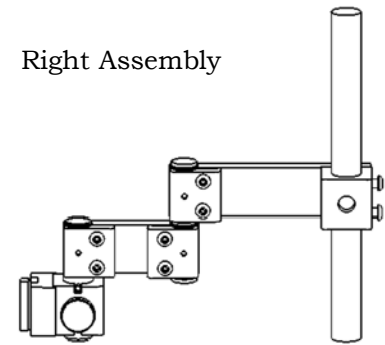
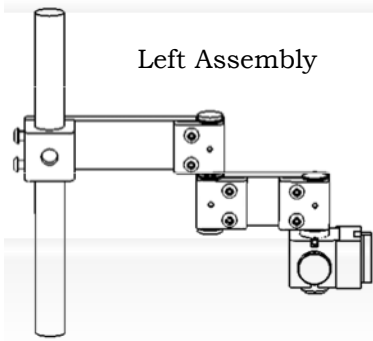

## Alternate Setup

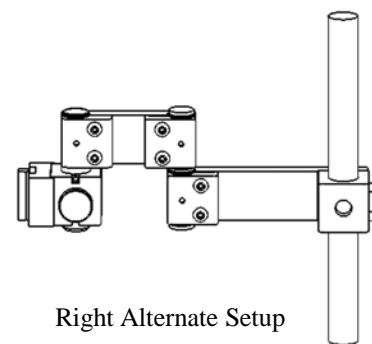
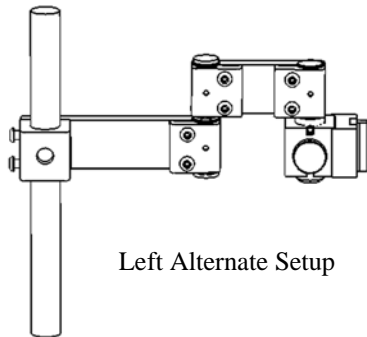

## Preparation

1. Locate and mark on the Keyed Back Cane of the wheelchair the patient's mid humeral area.

**Note:** The mount base needs to be attached a minimum of approximately 5 inches above or 8 inches below this mid humeral location. Alternate arm setup will decrease the amount of clearance needed when attached above marked location. See Alternate Setup images above.

2. If the relocater mount base is attached to the Mount Relocator, loosen Locking Knob and remove the mount base.
3. Remove the Slotted Mount Block from the Mount Adapter by inserting large T-Wrench into Attachment hole and turning counter clockwise.
4. Locate and remove the plastic cap from the top of the Keyed Back Cane of the wheelchair.

### Mount Base

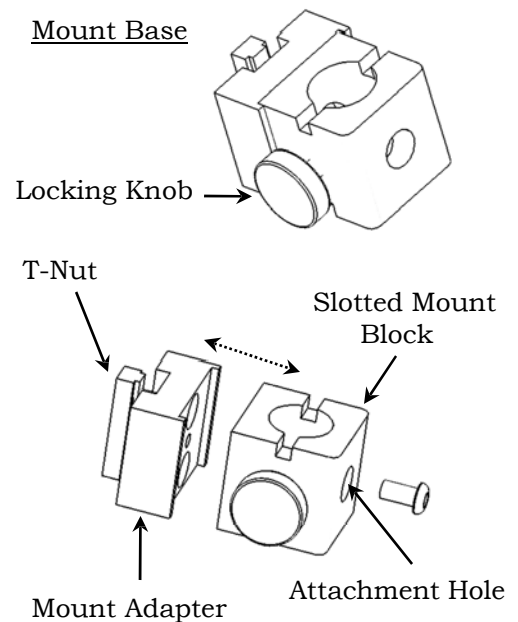

# ***JAEKO Table Mount*** **MultiLink**



The new Table Mount utilizes a MultiLink Arm to increase client functional range. Fits children through large adult, universal left or right.

# ***JAECO* Table Mount MultiLink with Elevation Assist**



The new Table Mount utilizes a MultiLink Arm with Elevation Assist to increase client functional range. Fits children through large adult, universal left or right.